

# MAX SEAL High Pressure Hydrogen Gas Needle Valve: Technical Specifications

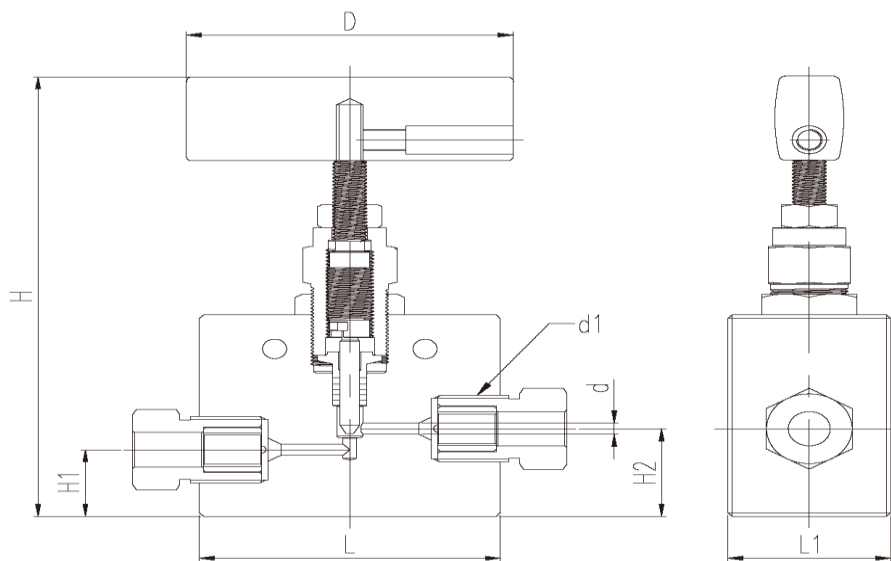

Valve	Pressure	Max.H70	
	Working Temperature	-40°C ~ +85°C	
	Cv	3/8"-60,000psi	0.32
	Body Material	STS316L	
	Seat/Stem	STS316L	
	Packing	PVDF+PFA	
	Handle	SCPH2	

Unit : mm

Nominal Diameter	Pressure Rating	d	d1	L	H1	H2	H	L1	D
1/4	20,000psi	2.8	7/16-20UNF	50	11.5	20.5	120	20	76
1/4	60,000psi	2.4	9/16-18UNF	50	16.5	22.5	120	30	76
3/8	20,000psi	5.2	9/16-18UNF	50	11.5	20.5	120	20	76

3/8	60,000psi	3.2	3/4-16UNF	50	16.5	22.5	120	30	76
9/16	20,000psi	7.9	13/16-16UNF	68	14	29	150	30	76
9/16	40,000psi	6.4	1 1/8-12UNF	68	19	30	140	38	76
9/16	60,000psi	4.8	1 1/8-12UNF	68	19	30	140	38	76

※ This Table is based on manufacturer's standard and can be changed at the request of customer.