

High pressure Hydrogen Pressure Relief Valve: Technical Specifications

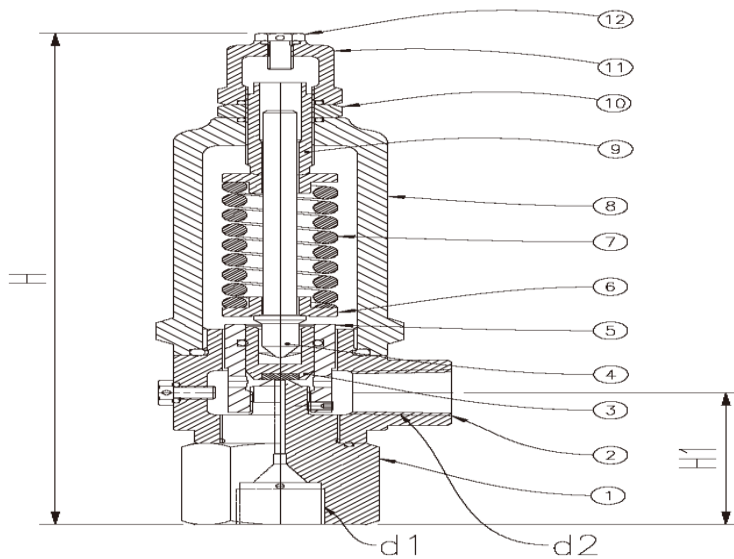

Pressure Rating	Max. H70
Working Temperature	-40°C ~ +85°C
Setting Pressure Tolerances	±3%
Seat Tightness Test	≥90% of Setting Pressure
Blow Down	≤15% of Setting Pressure
Hydrostaic Test Pressure	1.5times of MAWP
Back pressure Test	≥0.6MPa (87 psi)
Relieving Pressure	1.1times of Setting Pressure

No.1	Part Name	Material	Q'TY
1	BODY	STS316L	1
2	MAIN BOX	STS316L	1
3	DISC	Metal+Soft	1
4	STEM	STS316L	1

5	DISC GUIDE	STS316L	1
6	SPRING HOUSING	STS316L	2
7	SPRING	STS316L	1
8	SPRING BOX	STS316L	1
9	SPRING ADJUST SCREW	STS316L	1
10	LOCK NUT	STS316L	1
11	CAP	STS316L	1
12	LIFT SET BOLT	STS304	1

Unit : mm

Nominal Diameter	Pressure Rating	d1	d2	H	H1
1/4	20,000psi	7/16-20UNF	Rc 1/2	223.5	60
1/4	60,000psi	9/16-18UNF	Rc 1/2	223.5	60
3/8	20,000psi	9/16-18UNF	Rc 1/2	223.5	60
3/8	60,000psi	3/4-16UNF	Rc 1/2	223.5	60
9/16	20,000psi	13/16-16UNF	Rc 1/2	223.5	60
9/16	60,000psi	1 1/8-12UNF	Rc 1/2	223.5	60

※ This Table is based on manufacturer's standard and can be changed at the request of customer.