

CT-25-10000.GB

Highly compact, high-speed, electrically driven radial turbo compressor with gas bearing for the circulation and compression of various gases and refrigerants.

- High-speed gas bearings for oil free operation
- Lowest ratio of volume and weight versus pressure and mass flow due to highest speeds
- Aerodynamic and electromagnetic optimization for highest total efficiency
- Compatible to converter CC-550-7500
- Integrated temperature measurement for overload protection



Specifications turbo compressor

Maximum pressure ratio	2.1
Maximum mass flow	90 g/s
Maximum isentropic overall efficiency η_{tot}^1	64 %
Maximum speed	150,000 rpm
Acceleration time ²	<1.8 s
Maximum electric motor power demand	7 kW
Weight	8.8 kg (incl. cable)
Dimensions (L x W x H)	303 x 154 x 193 mm

Cooling

Liquid	50% / 50% water glycol mixture
Coolant temperature	-20 – 60 °C
In-/Outlet connector type	According to SAE J1231 430192
Tube ID	10 mm

Compressor map: overpressure operation

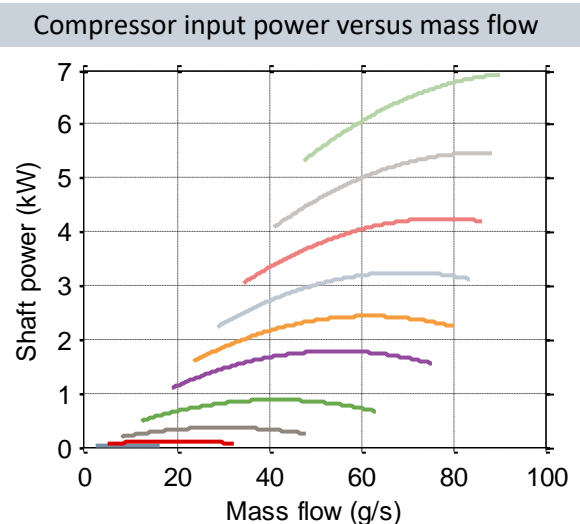
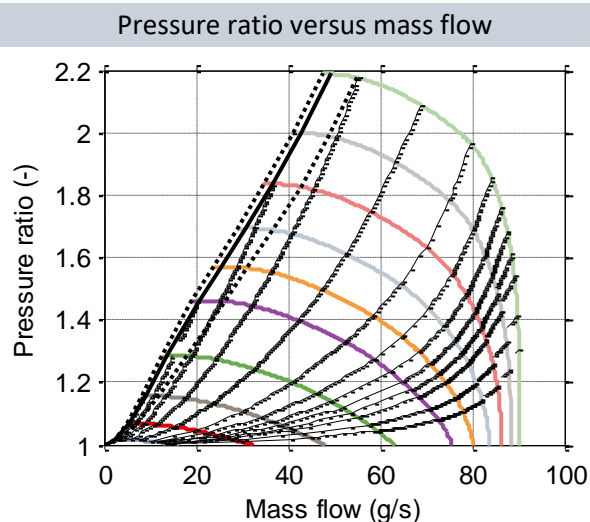

All rights reserved. All information in this document is based on Celeroton's best knowledge and is not to be considered as a warranty or quality specification. The information given is designed as a guidance and customers are requested to check the suitability and usability of the product in their specific application with consulting Celeroton. The information herein is subject to change without notification.



The specifications and compressor maps in this document for overpressure operation refer to air (ISO 8778) at the inlet of the compressor: temperature: $T = 293.15\text{ K} = 20^\circ\text{C}$, absolute pressure: $p_{in} = 1\text{ bar}$.



Depending on custom specific operation conditions such as e.g. gas inlet pressure and temperature, humidity, cooling conditions, the operation in environmental conditions with vibrations and/or depending on the combination of the compressor and the corresponding Celeroton converter, the compressor maps shown in this document may be different or may have additional limitations.

For technical details and further information, please refer to the user manual.

Order codes: CT-25-10000.GBxx

Bearing options GBxx

GB01 Air bearing at ISO 8778 inlet conditions

GB99 Custom specific gas bearing (inlet conditions and / or gas etc.)

Ordering information

Article number

CT-25-10000.GB01

4010032

Drawing in mm [inch]

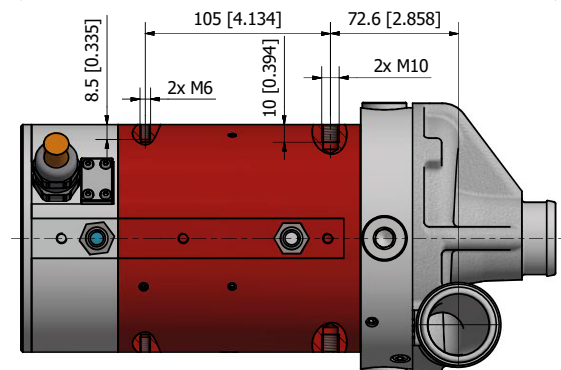
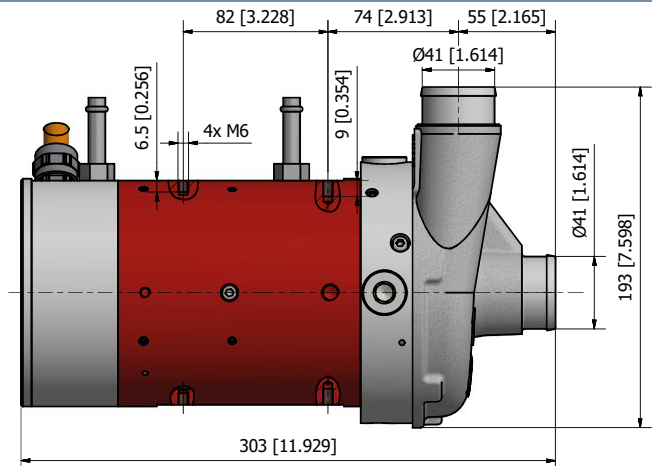
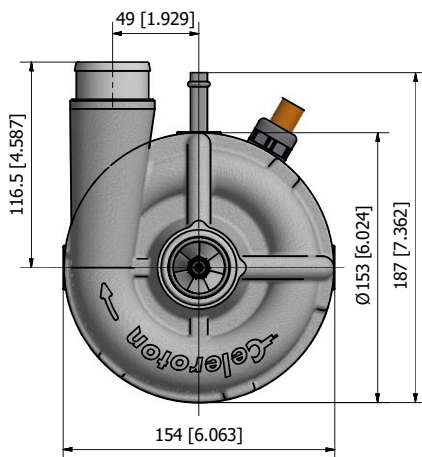

¹ $\eta_{tot} = \eta_{is} * \eta_m$: isentropic overall efficiency,

η_{is} : isentropic compressor efficiency,

η_m : motor and bearing efficiency

² 20 to 80% of maximum speed