

CC-120-1000



Converter for driving ultra-high-speed turbo compressors in fuel cells

- Sensorless speed control from 5,000 rpm up to 500,000 rpm
- Auxiliary voltage supply (8 – 32 VDC) for startup of the turbo compressor from battery, automatic switch to fuel cell voltage
- Operation of the compressor from wide output voltage range of the fuel cell (40 – 120 VDC)
- Rated output power: 1,000 W
- Protection class IP67
- 94% efficiency
- Integrated break chopper
- Connection to active and passive cooling (water or air) possible



Specifications converter

Input voltage U_{in} (DC) ¹	40 – 120 V
Input voltage auxiliary supply U_{in} (DC)	8 – 32 V
Rated output power	1,000 W
Output voltage (peak value phase-phase)	0 – 100 V
Maximum phase current (PAM-operation)	8.5 Arms / 12 A _{peak} ²
Maximum frequency / speed (PAM-operation)	8.3 kHz / 500,000 rpm
Communication interface	CAN
Weight (incl. housing)	1.4 kg
Dimensions (L x W x H)	172 x 138 x 53 mm

¹ Other voltage ranges on request

² Fundamental of the PAM-block current

User interfaces (X1, X2)

Connector X1 – In-/output (14 Pin)

3 x CAN interface	CanH, CanL, CanGND
2 x Serial service interface	TxD, RxD
1 x Auxiliary power supply (DC)	8 – 32 V
1 x GND	Reference potential auxiliary supply
3 x Input voltage (DC)	40 – 120 V
3 x GND	Reference potential input voltage
1 x PE	Protective earth input

Connector X2 – In-/output (8 Pin)

1 x Temperature measurement input	PT100
1 x GND	Reference potential temperature measurement
3 x Motor phase	PHA, PHB, PHC
3 x PE	Protective earth motor

Operating range

The operating range of the CC-120-1000 in FCO depends on the fuel cell input voltage as shown in Figure 1. The maximum continuous output power of 1,000 W can be obtained with an input voltage of 60-120 VDC. The absolute maximum power of 1,200 W can be reached during short time overload operation.

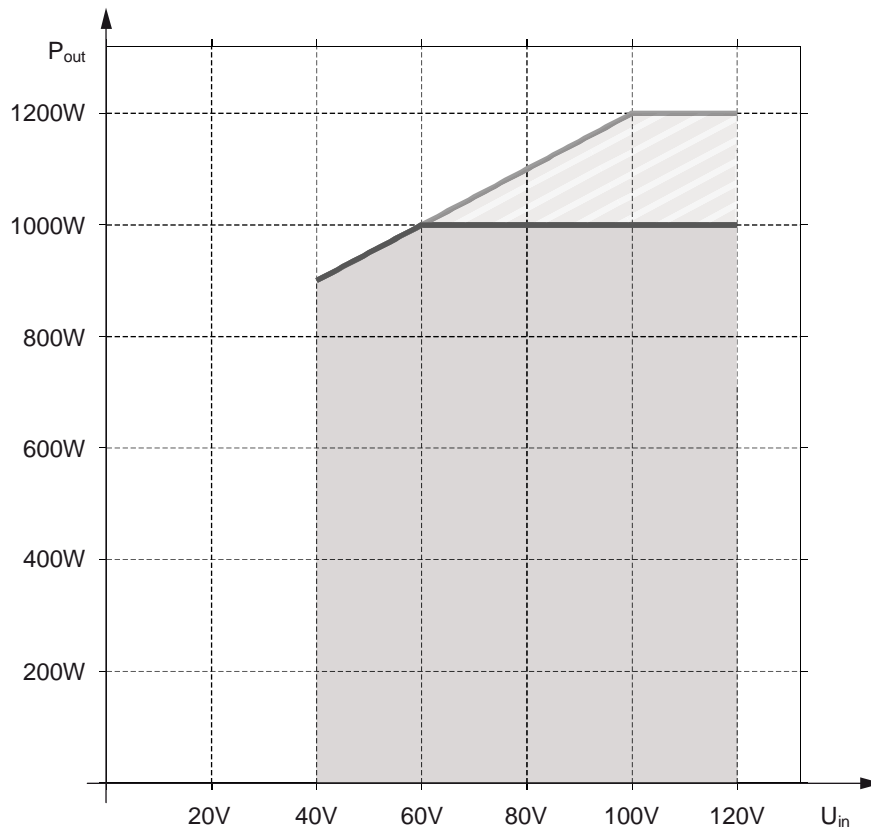
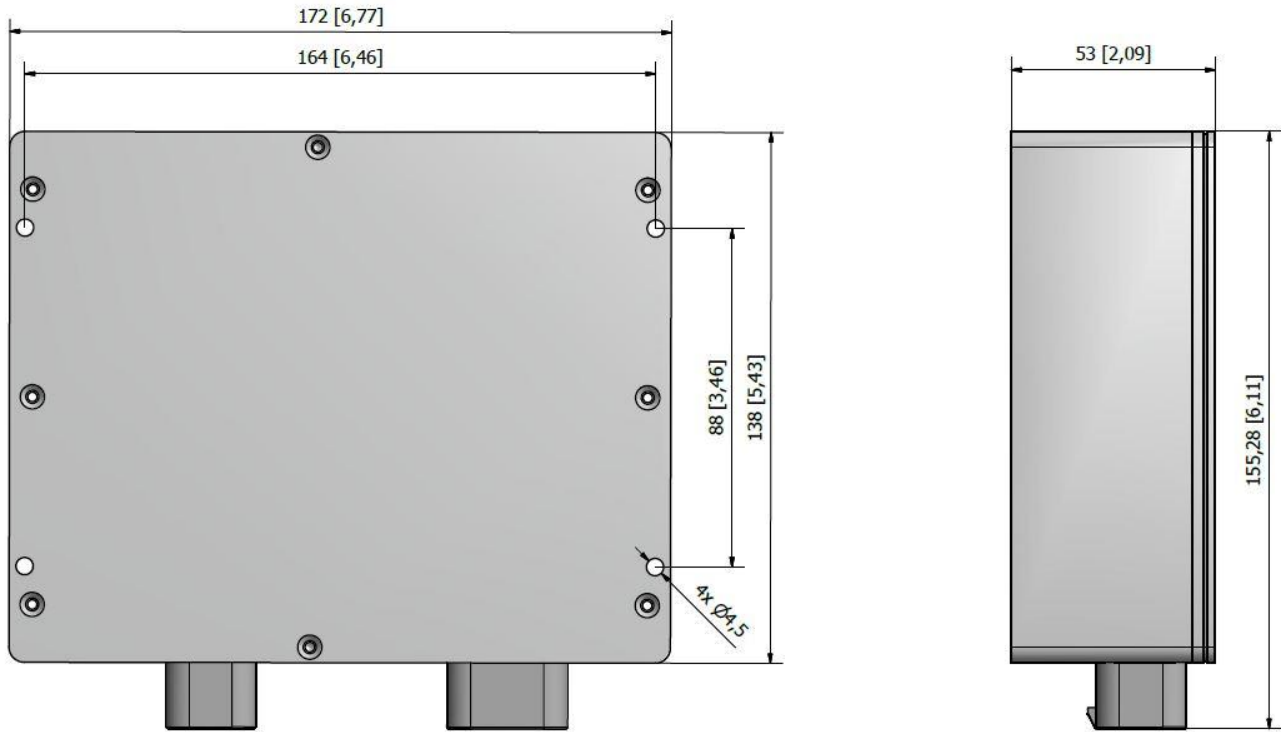

Figure 1: CC-120-1000 operating range. The continuous output power over fuel cell input voltage is shown as solid area. The short time overload operating range is shown as hatched area.



Celeroton AG
Industriestrasse 22
CH-8604 Volketswil

Tel.: +41 44 250 52 20
Fax: +41 44 250 52 29

info@celeroton.com
www.celeroton.com

© Celeroton AG. All rights reserved.