



Intro

Overview
Process Industry

Faster and More
Efficient – From
Planning to Plant
System Operations

Optimise Your Plant
System Maintenance

Step by Step
to More Efficiency

Contact

Process Industry

Water and Wastewater Management

More Efficiency for Your Industry



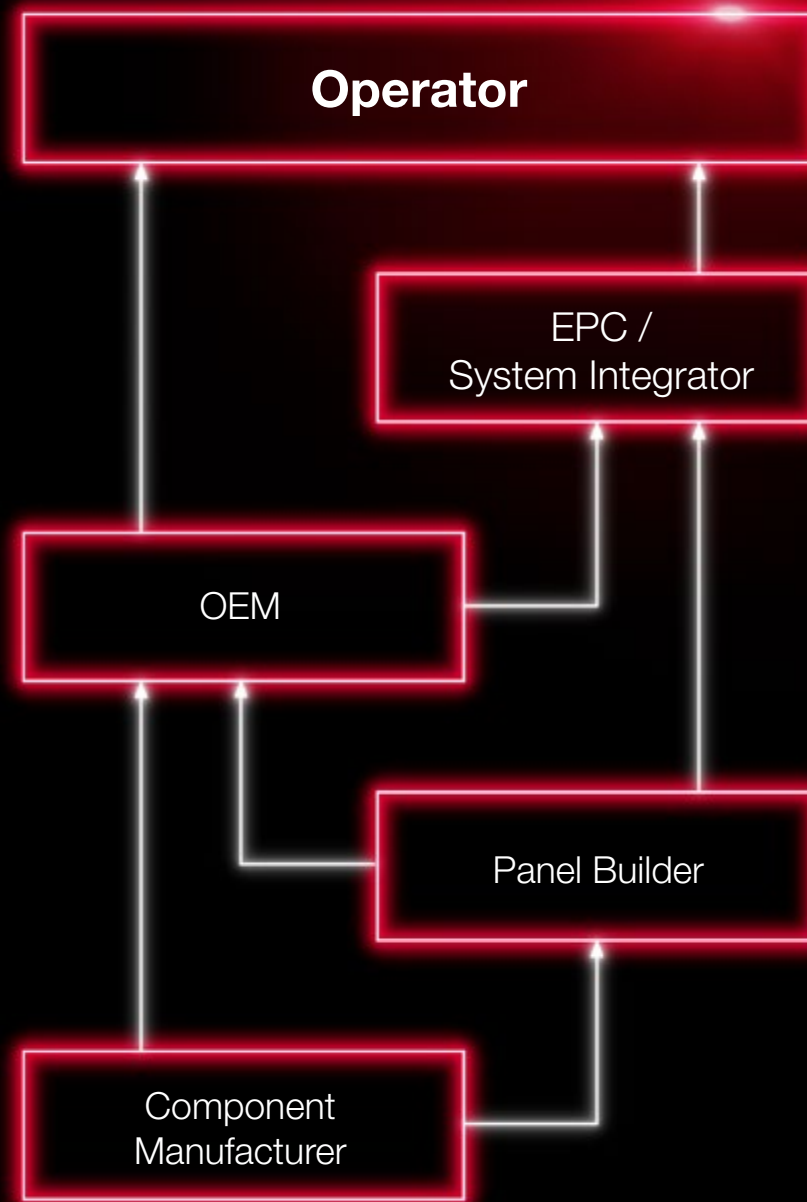

Digitalised Process for Water Suppliers and Wastewater Treatment

Our world's limited resources make sustainable water supplies and wastewater management an imperative. Along with environmental policy aspects, the industry is faced with a multitude of technical and economic challenges. Efficient engineering makes an important contribution to a secure the water supply and wastewater treatment. From plant design through to operation, you benefit from consistent data continuity and a high degree of standardisation.

EPLAN offers you field-tested, integrated solutions for water and wastewater treatment with the following added value:

- Connecting the fields of process technology, instrumentation technology and control technology plus the fluid power and electrical engineering
- Smooth workflows – from planning and design to service and maintenance of your plant systems
- Symbol libraries standardised to code and standardised planning templates in all trades
- An integrated data basis simplifies cooperation across trades and departments to keep everything on schedule
- Tools for planning service and maintenance work are based on always up-to-date, real-time depictions of the plant systems



Discover more:

www.eplan-software.com/process



[Intro](#)

[Overview
Process Industry](#)

[Faster and More
Efficient – From
Planning to Plant
System Operations](#)

[Optimise Your Plant
System Maintenance](#)

[Step by Step
to More Efficiency](#)

[Contact](#)

Your Engineering Standard for All Branches of the Process Industry

One industry, many different sectors with various challenges and requirements. EPLAN offers you data continuity, planning security and optimised processes for the oil and gas industry, the pharmaceutical and chemical industries, and for water suppliers and the wastewater treatment sector amongst others. Our solutions give you the possibility of optimising your processes in an integrated way.

Solutions for Generating Process Flow Diagrams and P&I Diagrams

What applies for process engineering holds true for all engineering disciplines: by complying with codes and standards and using high-quality component data as a basis for engineering, you create the critical foundation for efficient processes and workflows. With EPLAN Preplanning, you create plant overviews like PFDs and P&IDs added with PCT loop capture, PCT management and loop instrumentation.



Intro

Overview
Process Industry

Faster and More
Efficient – From
Planning to Plant
System Operations

Optimise Your Plant
System Maintenance

Step by Step
to More Efficiency

Contact

1

2

Faster and More Efficient – From Planning to Plant System Operations

For wastewater management companies, the focus is on the trouble-free removal of surface water via sewer systems to sewage treatment plants as well as reprocessing and return to the water cycle. One of today's biggest challenges for such plants is removing chemical residues such as fertilisers or medications from wastewater.

Your company's continuous development therefore makes an important contribution to society:

- Treated, high-quality water promotes general health.
- Modern wastewater management systems can prevent building damage and infrastructure problems caused by flooding.
- This creates sustainability and thus secures clean water supplies for future generations.



Intro

Overview
Process Industry

Faster and More
Efficient – From
Planning to Plant
System Operations

Optimise Your Plant
System Maintenance

Step by Step
to More Efficiency

Contact

1

2

Faster and More Efficient – From Planning to Plant System Operations

The entire range of solutions offered by EPLAN Platform, **particularly EPLAN Preplanning and Electric P8** as well as **consulting offerings** support you in mastering today's challenges.

Your added value:

- Plan, build and expand new facilities easily and efficiently
- Depict existing systems in a structured way and maintain them confidently
- Documentation from planning and operation generated at the push of a button supports further aspects such as those of fail-safety or procurement.

Optimise Your Plant System Maintenance

With integrated digital engineering documentation, all the necessary data for maintenance of buildings, plants and components is available at the push of a button. This saves you time and money by avoiding unnecessary delays in maintenance work.

Your added value:

- Planning and supply security
- Plant system availability
- Reliable service for safe operation

The EPLAN Platform solutions support your wastewater treatment plant and pumping stations in an integrated way. With EPLAN eVIEW, engineering documentation is available for all project participants at any time and from any location – for service technicians via tablet computer, even directly onsite in the plant. A wide range of functions, including clearly definable access rights and revisions via redlining and greenlining, support your project progress.



Step by Step to More Efficiency

EPLAN Experience is a concept that provides you with specific recommendations for action for process optimisation. It shows you how you can work in a functionally structured way and follow common standards. You can use this solid foundation to increase your engineering efficiency step by step.

The focus is on eight fields of action. This can be a specific subject area in your company, or a process that shows the potential for optimised engineering. Everything can be implemented, but it doesn't have to be. The concept has an open design: your tasks and assignments determine the need for action – regardless of company size, location or industry.

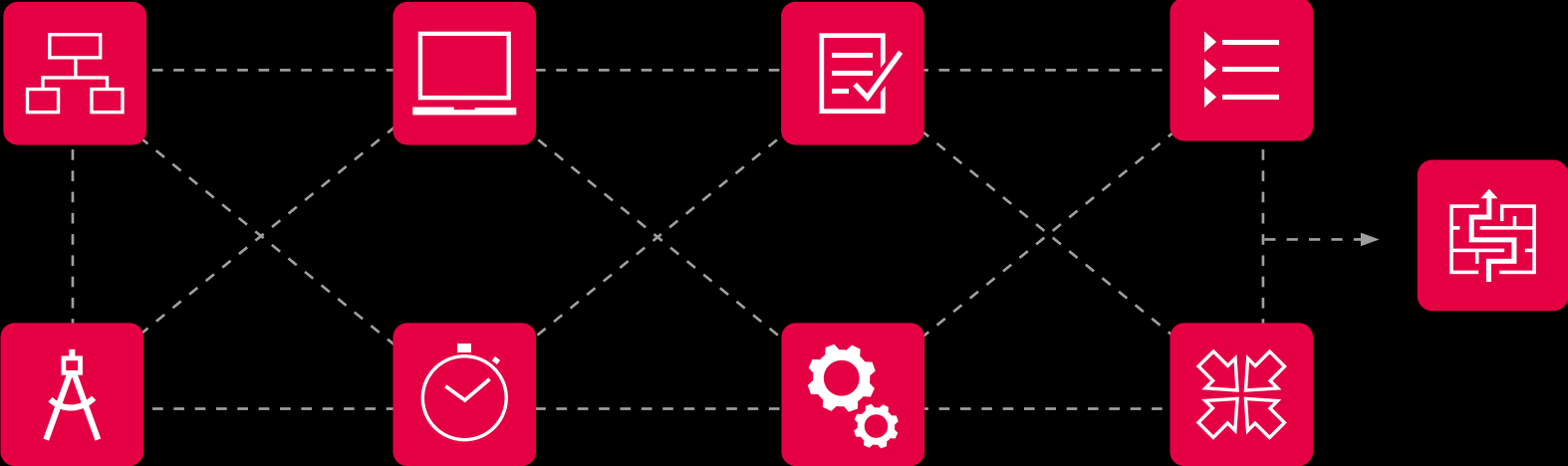



Intro

Overview
Process Industry

Faster and More
Efficient – From
Planning to Plant
System Operations

Optimise Your Plant
System Maintenance

Step by Step
to More Efficiency

Contact



Discover more:

www.eplan-software.com/process

EPLAN GmbH & Co. KG

An der alten Ziegelei 2
40789 Monheim am Rhein
Germany

Phone: +49 (0)2173 3964-0

Fax: +49 (0)2173 3964-25

info@eplan.de

www.eplan-software.com

PROCESS CONSULTING

ENGINEERING SOFTWARE

IMPLEMENTATION

GLOBAL SUPPORT

FRIEDHELM LOH GROUP

