

GEMÜ BB06

Compact flanged ball valve with bare shaft

EN

Operating instructions



further information
webcode: GW-BB06



All rights including copyrights or industrial property rights are expressly reserved.

Keep the document for future reference.

© GEMÜ Gebr. Müller Apparatebau GmbH & Co. KG
07.02.2024

Contents

1	General information	4
1.1	Information	4
1.2	Symbols used	4
1.3	Definition of terms	4
1.4	Warning notes	4
2	Safety information	5
3	Product description	5
3.1	Construction	5
3.2	Pressure-relief hole	5
3.3	Control ball	6
3.4	Description	6
3.5	Function	6
4	GEMÜ CONEXO	6
5	Correct use	6
6	Order data	8
7	Technical data	9
7.1	Medium	9
7.2	Temperature	9
7.3	Pressure	9
7.4	Product conformities	12
7.5	Mechanical data	12
8	Dimensions	13
9	Manufacturer's information	16
9.1	Delivery	16
9.2	Packaging	16
9.3	Transport	16
9.4	Storage	16
10	Installation in piping	16
10.1	Preparing for installation	16
10.2	Installation with flanged connections	17
10.3	After the installation	17
11	Commissioning	17
12	Operation	17
13	Troubleshooting	18
14	Inspection/maintenance	19
15	Removal from piping	19
16	Disposal	19
17	Returns	19
18	Declaration of conformity according to 2014/68/ EU (Pressure Equipment Directive)	20

1 General information

1.1 Information

- The descriptions and instructions apply to the standard versions. For special versions not described in this document the basic information contained herein applies in combination with any additional special documentation.
- Correct installation, operation, maintenance and repair work ensure faultless operation of the product.
- Should there be any doubts or misunderstandings, the German version is the authoritative document.
- Contact us at the address on the last page for staff training information.

1.2 Symbols used

The following symbols are used in this document:

Symbol	Meaning
●	Tasks to be performed
▶	Response(s) to tasks
-	Lists

1.3 Definition of terms

Working medium

The medium that flows through the GEMÜ product.

Control medium

The medium whose increasing or decreasing pressure causes the GEMÜ product to be actuated and operated.

Control function

The possible actuation functions of the GEMÜ product.

1.4 Warning notes

Wherever possible, warning notes are organised according to the following scheme:

SIGNAL WORD	
Possible symbol for the specific danger	<p>Type and source of the danger</p> <ul style="list-style-type: none"> ▶ Possible consequences of non-observance. ● Measures for avoiding danger.

Warning notes are always marked with a signal word and sometimes also with a symbol for the specific danger.

The following signal words and danger levels are used:



⚠ DANGER	
	<p>Imminent danger!</p> <ul style="list-style-type: none"> ▶ Non-observance can cause death or severe injury.

⚠ WARNING	
	<p>Potentially dangerous situation!</p> <ul style="list-style-type: none"> ▶ Non-observance can cause death or severe injury.

⚠ CAUTION	
	<p>Potentially dangerous situation!</p> <ul style="list-style-type: none"> ▶ Non-observance can cause moderate to light injury.

NOTICE	
	<p>Potentially dangerous situation!</p> <ul style="list-style-type: none"> ▶ Non-observance can cause damage to property.

The following symbols for the specific dangers can be used within a warning note:

Symbol	Meaning
	Danger of explosion!
	Corrosive chemicals!
	Hot plant components!

2 Safety information

The safety information in this document refers only to an individual product. Potentially dangerous conditions can arise in combination with other plant components, which need to be considered on the basis of a risk analysis. The operator is responsible for the production of the risk analysis and for compliance with the resulting precautionary measures and regional safety regulations.

The document contains fundamental safety information that must be observed during commissioning, operation and maintenance. Non-compliance with these instructions may cause:

- Personal hazard due to electrical, mechanical and chemical effects.
- Hazard to nearby equipment.
- Failure of important functions.
- Hazard to the environment due to the leakage of dangerous substances.

The safety information does not take into account:

- Unexpected incidents and events, which may occur during installation, operation and maintenance.
- Local safety regulations which must be adhered to by the operator and by any additional installation personnel.

Prior to commissioning:

1. Transport and store the product correctly.
2. Do not paint the bolts and plastic parts of the product.
3. Carry out installation and commissioning using trained personnel.
4. Provide adequate training for installation and operating personnel.
5. Ensure that the contents of the document have been fully understood by the responsible personnel.
6. Define the areas of responsibility.
7. Observe the safety data sheets.
8. Observe the safety regulations for the media used.

During operation:

9. Keep this document available at the place of use.
10. Observe the safety information.
11. Operate the product in accordance with this document.
12. Operate the product in accordance with the specifications.
13. Maintain the product correctly.
14. Do not carry out any maintenance work and repairs not described in this document without consulting the manufacturer first.

In cases of uncertainty:

15. Consult the nearest GEMÜ sales office.

3 Product description

3.1 Construction

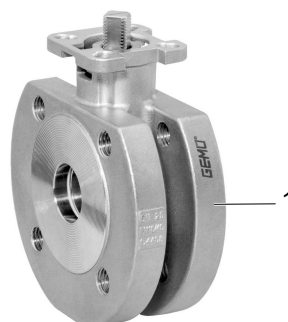

Item	Name	Materials
1	Ball valve body	1.4408 investment casting (316)
	Ball	1.4401 investment casting (316)
	Seal material	PTFE

3.2 Pressure-relief hole



3.3 Control ball

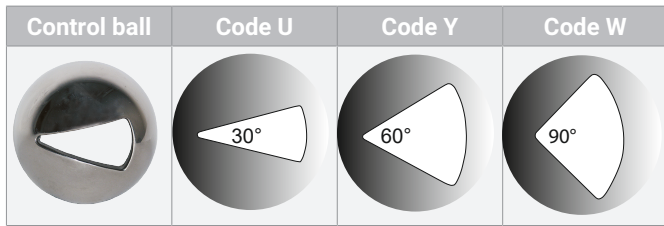

Note: The control ball cannot be retrofitted to standard 2/2-way bodies at a later date.

3.4 Description

The GEMÜ BB06 metal one-piece 2/2-way ball valve has a bare shaft. The seat seal is made of PTFE.

3.5 Function

The product is designed for use in piping. It controls a flowing medium after a manual actuator (see GEMÜ B26), pneumatic actuator (see GEMÜ B46) or motorized actuator (see GEMÜ B56) has been mounted.

4 GEMÜ CONEXO

Installing the RFID chip

In the corresponding design with CONEXO, this product has an RFID chip (1) for electronic recognition. The position of the RFID chip can be seen below.

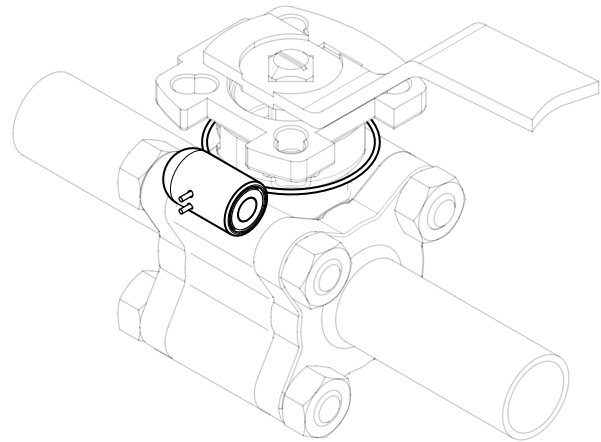

5 Correct use

Ball valves are used to isolate media flows.

Only clean, liquid or gaseous media must be used, and the body and seal materials used must be resistant to and suitable for this. Contaminated media and / or applications outside of the pressure and temperature data may lead to damage to the body and, in particular, to the seals on the ball valve.

The "Technical data" chapter describes the permissible pressure / temperature range for these ball valves.

⚠ DANGER	
	<p>Danger of explosion!</p> <ul style="list-style-type: none"> ▶ Risk of severe injury or death ● Do not use the product in potentially explosive zones. ● Only use the product in potentially explosive zones confirmed in the declaration of conformity.

⚠ WARNING	
<p>Improper use of the product!</p> <ul style="list-style-type: none"> ▶ Risk of severe injury or death ▶ Manufacturer liability and guarantee will be void. ● Only use the product in accordance with the operating conditions specified in the contract documentation and in this document. 	

The product is designed for installation in piping systems and for controlling a working medium.

1. Use the product in accordance with the technical data.
2. Note the supplement acc. to ATEX

Due to the design, in the open and closed position, a low volume of medium may be trapped within the ball or between the ball and the body.

Expansion of the medium due to temperature differences, change in state or a chemical response may lead to a high pressure build-up. In order to prevent unacceptable pressure increases, a special version with pressure-relief hole in the ball is available on request for this case.

NOTICE

Build-up of lint!

- ▶ For soft-seated ball valves, due to the relative rotations of the stainless steel ball to the seat seal, slight wear of the PTFE seals must always be anticipated. Despite this, the safety of the ball valve is not affected by any potential build-up of lint and the seal materials are compliant in accordance with FDA directives.

6 Order data

The order data provide an overview of standard configurations.

Please check the availability before ordering. Other configurations available on request.

Products ordered with **bold marked ordering options** are so-called preferred series. Depending on the nominal size, these are available more quickly.

Order codes

1 Type	Code
Ball valve body, metal, one-piece body, compact flange, ISO 5211, top flange, low-maintenance spindle seal and blow-out proof shaft, with anti-static unit	BB06

2 DN	Code
DN 15	15
DN 20	20
DN 25	25
DN 32	32
DN 40	40
DN 50	50
DN 65	65
DN 80	80
DN 100	100

3 Body/ball configuration	Code
2/2-way body	D
2/2-way body, V-ball 30° (for Kv value see datasheet)	U
2/2-way body, V-ball 60° (for Kv value see datasheet)	Y
2/2-way body, V-ball 90° (for Kv value see datasheet)	W

4 Connection type	Code
Flange ANSI Class 125/150 RF, face-to-face dimension FTF EN 558 series 1, ISO 5752, basic series 1, length only for body configuration D	39
Flange EN 1092, PN16/PN40, form B DN15 to DN50, flange EN1092, PN 16, form B DN65 to DN100	68

5 Ball valve material	Code
1.4408 / CF8M (body, connection), 1.4401 / SS316 (ball, shaft)	37

6 Seal material	Code
PTFE	5

7 Type of design	Code
Standard	
Thermal separation between actuator and valve body via mounting kit	5222
Thermal separation between actuator and valve body via mounting kit, mounting kit and mounting parts made from stainless steel	5227
K-no. 5227, K-no. 7056, 5227 - Thermal separation via mounting kit, 7056 - Drilled shaft, shortened hand lever	5237
Hand lever shortened to set up feedback units. Shaft face drilled for mounting kit: DN8-DN20 M5 X 12,5 / depth of thread 9.0mm, DN25-DN100 M6 x 15 / depth of thread 10.0mm	7056

8 Special version	Code
Without	
ATEX certification	X

9 CONEXO	Code
Without	
Integrated RFID chip for electronic identification and traceability	C

Order example

Ordering option	Code	Description
1 Type	BB06	Ball valve body, metal, one-piece body, compact flange, ISO 5211, top flange, low-maintenance spindle seal and blow-out proof shaft, with anti-static unit
2 DN	25	DN 25
3 Body/ball configuration	D	2/2-way body
4 Connection type	39	Flange ANSI Class 125/150 RF
5 Ball valve material	37	1.4408 / CF8M (body, connection), 1.4401 / SS316 (ball, shaft)
6 Seal material	5	PTFE
7 Type of design		Without
8 Special version		Standard
9 CONEXO		Without

7 Technical data

7.1 Medium

Working medium: Corrosive, inert, gaseous and liquid media and steam which have no negative impact on the physical and chemical properties of the body and seal material.

7.2 Temperature

Media temperature: -40 – 180 °C
For media temperatures > 100 °C, we recommend using a mounting kit with adapter between the ball valve and the actuator.

Ambient temperature: -40 – 60 °C
Higher temperatures on request

Storage temperature: -60 – 60 °C

7.3 Pressure

Operating pressure: 0 – 40 bar

Vacuum: Can be used up to a vacuum of 50 mbar (absolute)
These values apply to room temperature and air. The values may deviate for other media and other temperatures.

Leakage rate: Leakage rate according to ANSI FCI70 – B16.104
Leakage rate according to EN12266, 6 bar air, leakage rate A

Pressure/temperature diagram:

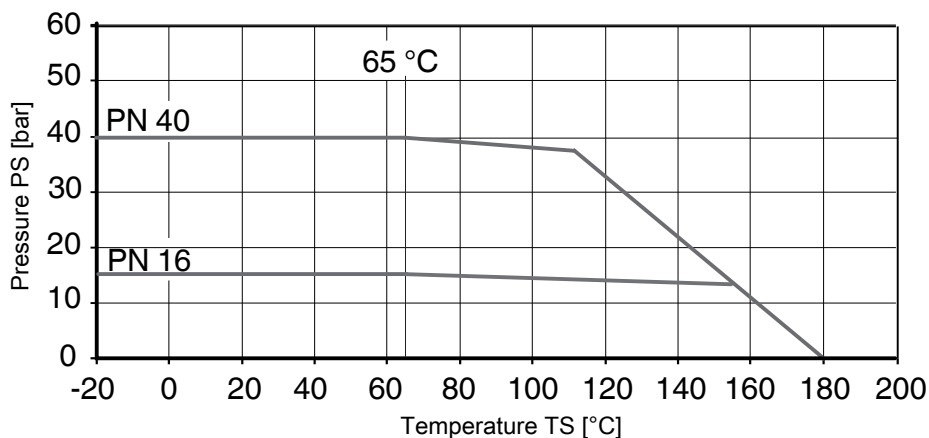

Pressure/temperature data according to the diagram refer to static operating conditions. Strongly fluctuating parameters or parameters that change quickly over time can lead to a reduction in service life. Special applications are to be discussed with your technical contact in advance.

Pressure rating: DN 15 – 50: PN40
DN 65 – 100: PN16

Kv values:

DN	NPS	Kv values
15	1/2"	13.0
20	3/4"	34.0
25	1"	60.0
32	1¼"	94.0
40	1½"	213.0
50	2"	366.0
65	2½"	595.0
80	3"	935.0
100	4"	1700.0

Kv values in m³/h

V-ball 30° (code U)

DN	NPS	Opening angle										
		0	15%	20%	30%	40%	50%	60%	70%	80%	90%	100%
15	1/2"	0	0.085	0.085	0.170	0.255	0.425	0.680	0.935	1.360	1.870	2.210
20	3/4"	0	0.085	0.170	0.425	0.595	0.935	1.530	2.040	2.805	3.825	4.590
25	1"	0	0.085	0.255	0.680	1.105	1.955	2.975	4.335	5.961	8.128	8.500
32	1¼"	0	0.170	0.340	0.935	1.700	3.145	4.675	6.800	8.500	11.050	12.750
40	1½"	0	0.255	0.510	1.360	2.550	4.250	6.375	9.350	11.900	14.450	17.000
50	2"	0	0.340	1.020	3.230	5.100	8.500	12.75	19.550	26.350	36.550	51.000
65	2½"	0	0.340	0.850	3.400	6.800	10.200	15.300	23.800	31.450	52.70	63.750
80	3"	0	0.425	1.020	3.400	6.800	11.900	19.550	28.050	39.100	55.250	69.700
100	4"	0	0.510	1.700	5.100	12.750	24.650	40.800	60.350	85.000	110.50	135.20

Kv values in m³/h

V-ball 60° (code Y)

DN	NPS	Opening angle										
		0	15%	20%	30%	40%	50%	60%	70%	80%	90%	100%
15	1/2"	0	0.085	0.085	0.255	0.425	0.765	1.190	1.700	2.805	3.740	5.100
20	3/4"	0	0.085	0.170	0.595	0.850	1.445	2.380	3.400	5.525	7.650	10.200
25	1"	0	0.170	0.340	0.935	1.530	2.890	4.505	6.715	10.46	13.010	17.850
32	1¼"	0	0.170	0.510	1.530	2.550	4.675	8.075	10.880	16.15	22.100	33.150
40	1½"	0	0.340	0.680	2.125	3.400	6.800	11.050	16.150	22.95	34.000	44.200
50	2"	0	0.340	1.275	3.910	7.650	14.030	22.950	33.150	46.75	70.550	93.500
65	2½"	0	0.340	1.275	4.250	8.500	17.850	28.900	45.050	63.75	87.550	127.50
80	3"	0	0.425	2.125	5.100	11.900	21.250	34.000	55.250	77.35	108.80	140.30
100	4"	0	0.595	2.550	9.350	21.250	34.000	50.150	76.500	119.9	180.20	302.60

Kv values in m³/h

Kv values:**V-ball 90° (code W)**

DN	NPS	Opening angle										
		0	15%	20%	30%	40%	50%	60%	70%	80%	90%	100%
15	1/2"	0	0.085	0.170	0.340	0.510	0.765	1.275	1.870	3.230	4.590	5.865
20	3/4"	0	0.170	0.340	0.680	1.020	1.700	2.635	3.910	6.800	9.605	11.900
25	1"	0	0.170	0.510	1.530	2.890	4.335	6.885	9.690	13.600	17.850	24.650
32	1¼"	0	0.255	0.680	1.700	4.250	6.800	11.900	16.150	23.800	33.150	46.750
40	1½"	0	0.425	0.765	2.975	5.950	11.050	17.000	26.350	35.700	53.550	66.300
50	2"	0	0.595	1.700	5.100	10.200	18.700	29.750	38.250	59.500	89.250	114.80
65	2½"	0	0.425	1.445	5.950	11.900	23.800	40.800	59.500	90.100	136.00	185.30
80	3"	0	0.595	2.975	6.800	15.300	29.750	51.000	76.500	114.80	174.30	263.50
100	4"	0	0.850	2.975	13.600	34.000	63.750	106.30	161.50	250.80	375.70	569.50





Kv values in m³/h

7.4 Product conformities

Pressure Equipment Directive: 2014/68/EU

Food: FDA
Regulation (EC) No. 10/2011
Regulation (EC) No. 1935/2006

Explosion protection: ATEX (2014/34/EU) and IECEx, order code Special version X

ATEX marking: **Up to DN 65**
Gas:  II 2G Ex h IIC T6 ... T2 Gb X
Dust:  II -/2D Ex h -/IIIC T180 °C -/Db X
DN 80 and 100
Gas:  II 2G Ex h IIB T6 ... T2 Gb X
Dust:  II -/2D Ex h -/IIIC T180 °C -/Db X

7.5 Mechanical data

Torques:

DN	NPS	Breakaway torque
15	1/2"	7
20	3/4"	8
25	1"	10
32	1¼"	14
40	1½"	29
50	2"	58
65	2½"	62
80	3"	120
100	4"	174

Torques in Nm

Weight:

Ball valve

DN	NPS	Weight
15	1/2"	1.3
20	3/4"	2.0
25	1"	2.8
32	1¼"	4.2
40	1½"	5.3
50	2"	6.7
65	2½"	11.9
80	3"	14.9
100	4"	20.4

Weights in kg

8 Dimensions

8.1 Actuator flange

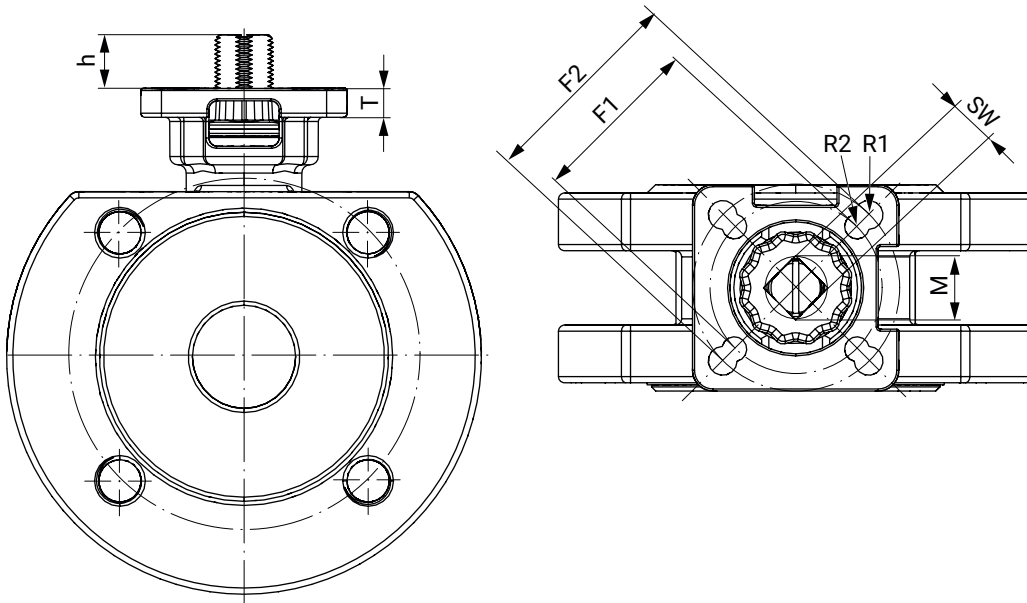

DN	G	F1	R1	F2	R2	SW	h	T	M
15	1/2"	36.0	3.0	42.0	3.0	9.0	9.0	5.0	M12
20	3/4"	36.0	3.0	42.0	3.0	9.0	7.5	5.0	M12
25	1"	42.0	3.0	50.0	3.5	11.0	13.0	7.0	M14
32	1¼"	42.0	3.0	50.0	3.5	11.0	13.0	7.0	M14
40	1½"	50.0	3.5	70.0	4.5	14.0	15.0	9.0	M18
50	2"	50.0	3.5	70.0	4.5	14.0	16.0	9.0	M18
65	2½"	70.0	5.0	102.0	6.0	17.0	18.0	10.5	M22
80	3"	70.0	5.0	102.0	6.0	17.0	18.0	10.5	M22
100	4"	70.0	5.0	102.0	6.0	17.0	18.0	10.5	M22

Dimensions in mm

8.2 Body dimensions

8.2.1 Flange (connection code 39)

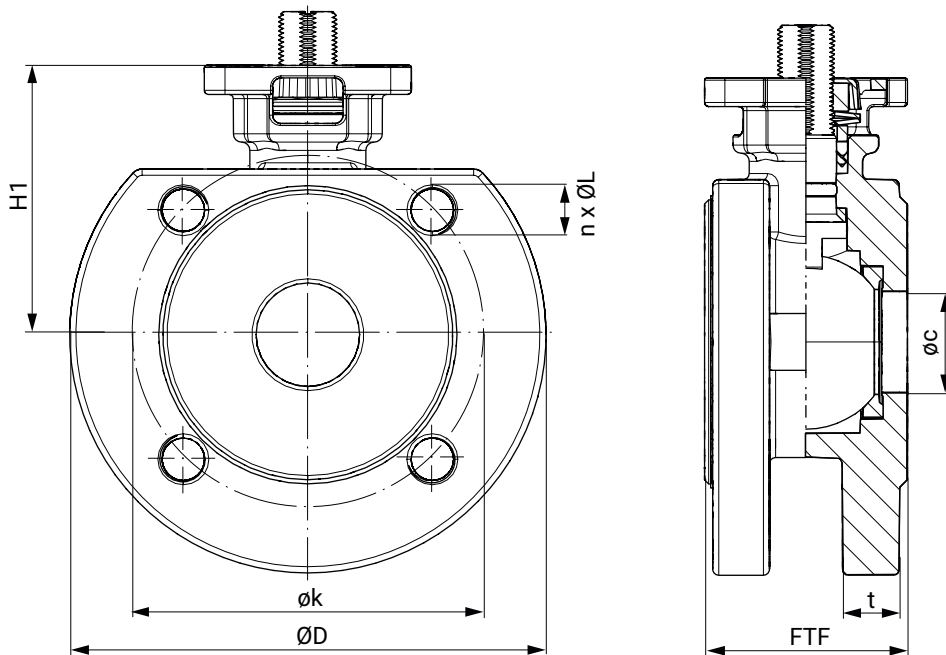

DN	øc	ØD	øk	t	FTF	H1	n x ØL
15	15.0	89.0	60.5	9.2	38.0	48.5	4x1/2-13UNC
20	20.0	99.0	69.8	11.0	40.0	54.0	4x1/2-13UNC
25	25.0	108.0	79.2	13.5	46.0	65.0	4x1/2-13UNC
32	32.0	117.0	88.9	14.0	56.0	78.0	4x1/2-13UNC
40	38.0	127.0	98.6	15.5	65.0	85.0	4x1/2-13UNC
50	50.0	152.0	120.6	17.0	78.0	93.0	4x5/8-11UNC
65	65.0	178.0	139.7	20.5	99.0	107.0	4x5/8-11UNC
80	76.0	190.0	152.4	22.0	116.0	119.0	4x5/8-11UNC
100	100.0	229.0	190.5	22.0	149.0	132.0	8x5/8-11UNC

Dimensions in mm

8.2.2 Flange (connection code 68)

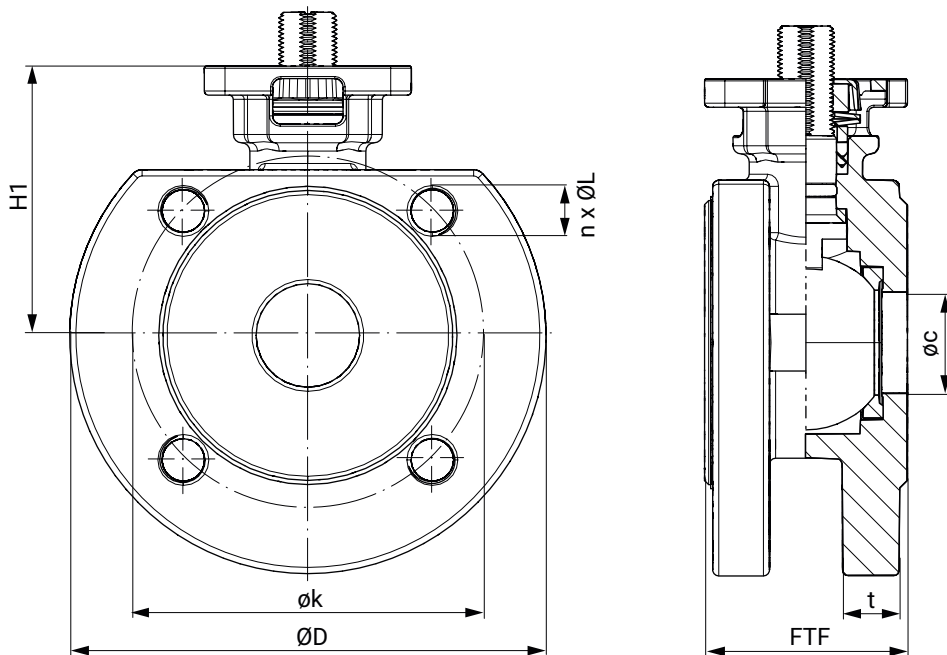

DN	ϕc	ϕD	ϕk	t	FTF	H1	n x ϕL
15	15.0	82.0	65.0	14.0	42.0	48.5	4 x M12
20	20.0	98.0	75.0	14.0	44.0	54.0	4 x M12
25	25.0	115.0	85.0	14.0	50.0	65.0	4 x M12
32	32.0	140.0	100.0	16.0	60.0	78.0	4 x M16
40	38.0	150.0	110.0	15.0	69.0	85.0	4 x M16
50	50.0	165.0	125.0	15.5	82.0	93.0	4 x M16
65	65.0	185.0	145.0	15.5	103.0	107.0	4 x M16
80	76.0	200.0	160.0	17.0	119.0	119.0	8 x M16
100	100.0	220.0	180.0	17.0	150.0	132.0	8 x M16

Dimensions in mm

9 Manufacturer's information

9.1 Delivery

- Check that all parts are present and check for any damage immediately upon receipt.

The product's performance is tested at the factory. The scope of delivery is apparent from the dispatch documents and the design from the order number.

9.2 Packaging

The product is packaged in a cardboard box which can be recycled as paper.

9.3 Transport

1. Only transport the product by suitable means. Do not drop. Handle carefully.
2. After the installation dispose of transport packaging material according to relevant local or national disposal regulations / environmental protection laws.



9.4 Storage



1. Store the product free from dust and moisture in its original packaging.
2. Avoid UV rays and direct sunlight.
3. Do not exceed the maximum storage temperature (see chapter "Technical data").
4. Do not store solvents, chemicals, acids, fuels or similar fluids in the same room as GEMÜ products and their spare parts.
5. Store the ball valves in the "open" position.

10 Installation in piping

10.1 Preparing for installation

 WARNING	
The equipment is subject to pressure!	
<ul style="list-style-type: none"> ▶ Risk of severe injury or death ● Depressurize the plant. ● Completely drain the plant. 	

 WARNING	
	Corrosive chemicals!
	<ul style="list-style-type: none"> ▶ Risk of caustic burns ● Wear appropriate protective gear. ● Completely drain the plant.

 CAUTION	
	Hot plant components!
	<ul style="list-style-type: none"> ▶ Risk of burns ● Only work on plant that has cooled down.

 CAUTION
Exceeding the maximum permissible pressure!
<ul style="list-style-type: none"> ▶ Damage to the product ● Provide precautionary measures against exceeding the maximum permitted pressures caused by pressure surges (water hammer).

 CAUTION
Use as step!
<ul style="list-style-type: none"> ▶ Damage to the product ▶ Risk of slipping-off ● Choose the installation location so that the product cannot be used as a foothold. ● Do not use the product as a step or a foothold.

NOTICE
Suitability of the product!
<ul style="list-style-type: none"> ▶ The product must be appropriate for the piping system operating conditions (medium, medium concentration, temperature and pressure) and the prevailing ambient conditions.

NOTICE
Tools!
<ul style="list-style-type: none"> ▶ The tools required for installation and assembly are not included in the scope of delivery. ● Use appropriate, functional and safe tools.

1. Ensure the product is suitable for the relevant application.
2. Check the technical data of the product and the materials.
3. Keep appropriate tools ready.
4. Wear appropriate protective gear, as specified in the plant operator's guidelines.
5. Observe appropriate regulations for connections.
6. Have installation work carried out by trained personnel.
7. Shut off plant or plant component.
8. Secure plant or plant component against recommissioning.
9. Depressurize the plant or plant component.
10. Completely drain the plant (or plant component) and let it cool down until the temperature is below the media vaporization temperature and cannot cause scalding.
11. Decontaminate, rinse and ventilate the plant or plant component properly.
12. Lay piping so that the product is protected against transverse and bending forces, and also from vibrations and tension.
13. Only mount the product between matching aligned pipes (see following chapters).
14. Flow direction and installation position are optional.

10.2 Installation with flanged connections

NOTICE

- Observe valid standards for mounting flanges!

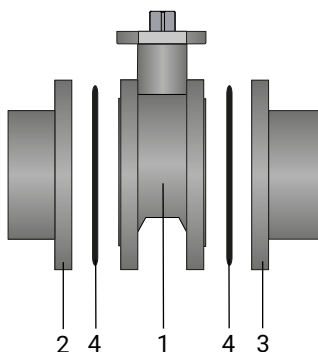

1. Ensure sealing surfaces on the mating flanges are clean and undamaged.
2. Only use connector elements made of approved materials.
3. Install the ball valve in the state it is delivered.
4. Carefully align the ball valve body **1** centrally between the pipes with flanges (**2** and **3**).
5. Centre the seals **4** accurately. Seals are not included in the scope of delivery.
6. Connect the ball valve flange and the piping flange using appropriate sealing material and matching bolting. Sealing material and bolts are not included in the scope of delivery.

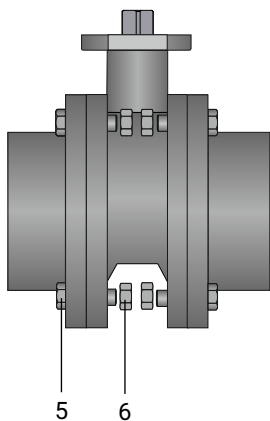

7. Insert bolts **5** in all holes in the flange.
8. Slightly tighten the bolts **5** and nuts **6** diagonally.

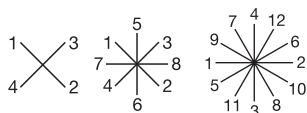

9. Check the alignment of the piping.
10. Tighten the nuts **6** diagonally.

Comply with appropriate regulations for the connections.

10.3 After the installation

- Re-attach or reactivate all safety and protective devices.

11 Commissioning

WARNING



Corrosive chemicals!

- Risk of caustic burns
- Wear appropriate protective gear.
- Completely drain the plant.

CAUTION

Leakage

- Emission of dangerous materials.
- Provide precautionary measures against exceeding the maximum permitted pressures caused by pressure surges (water hammer).

1. Check the tightness and the function of the product (close and reopen the product).
2. Flush the piping system of new plant and following repair work (the product must be fully open).
 - ⇒ Harmful foreign matter has been removed.
 - ⇒ The product is ready for use.
3. Commission the product.

12 Operation



The product is operated via manual, pneumatic or motorized actuators.

- Observe the enclosed actuator instructions.

13 Troubleshooting

Error	Possible cause	Troubleshooting
The product does not open or does not open fully	Operating pressure too high	Operate the product with operating pressure specified in datasheet
	Foreign matter in the product	Remove and clean the product
The product does not close or does not close fully	Operating pressure too high	Operate the product with operating pressure specified in datasheet
	Foreign matter in the product	Remove and clean the product
Connection between valve body and piping leaking	Incorrect installation	Check installation of valve body in piping
	Flange bolting loose/thread leaking	Retighten flange bolting / reseal threads
	Flange seals faulty	Replace flange seals
	Sealing material faulty	Replace sealing material
	Threaded connections / unions loose	Tighten threaded connections / unions
Valve body leaking	Incorrect installation	Check installation of valve body in piping
	Seat and flange seals incorrectly mounted	Mount seat and flange seals correctly
	Seat and flange seals faulty	Replace seat and flange seals
	Valve body leaking or corroded	Check valve body for damage, replace valve body if necessary

14 Inspection/maintenance

 CAUTION	
	<p>Hot plant components!</p> <ul style="list-style-type: none"> ▶ Risk of burns ● Only work on plant that has cooled down.

 WARNING	
<p>The equipment is subject to pressure!</p> <ul style="list-style-type: none"> ▶ Risk of severe injury or death ● Depressurize the plant or plant component. ● Completely drain the plant or plant component. 	

 CAUTION	
<ul style="list-style-type: none"> ● Servicing and maintenance work must only be performed by trained personnel. ● In case of doubt, contact GEMÜ prior to commissioning. 	

1. Use appropriate protective gear as specified in plant operator's guidelines.
2. Shut off plant or plant component.
3. Secure against recommissioning.
4. Depressurize the plant or plant component.

Ball valves are maintenance-free. No lubrication or routine maintenance of the ball valve shaft is required. The shaft is guided through a PTFE gland packing in the ball valve body. The shaft seal is pretensioned and self-adjusting. However, the operator must carry out regular visual examinations of the ball valves, dependent on the operating conditions and the potential danger in order to prevent leakage and damage.

If there is a leakage at the spindle nut, this can generally be rectified by retightening the spindle nut. However, overtightening the spindle nut must be avoided.

Usually, retightening by between 30° and 60° will be sufficient to rectify the leakage.

15 Removal from piping

1. Remove the clamp or screw connections in reverse order to installation.
2. Remove welded or solvent cemented connections using a suitable cutting tool.
3. Observe the safety information and accident prevention regulations.

16 Disposal

1. Pay attention to adhered residual material and gas diffusion from penetrated media.
2. Dispose of all parts in accordance with the disposal regulations/environmental protection laws.

17 Returns

Legal regulations for the protection of the environment and personnel require that the completed and signed return delivery note is included with the dispatch documents. Returned goods can be processed only when this note is completed. If no return delivery note is included with the product, GEMÜ cannot process credits or repair work but will dispose of the goods at the operator's expense.

1. Clean the product.
2. Request a return delivery note from GEMÜ.
3. Complete the return delivery note.
4. Send the product with a completed return delivery note to GEMÜ.

18 Declaration of conformity according to 2014/68/EU (Pressure Equipment Directive)

EU Declaration of Conformity

in accordance with 2014/68/EU (Pressure Equipment Directive)

We, the company
GEMÜ Gebr. Müller Apparatebau GmbH & Co. KG
Fritz-Müller-Strasse 6-8
74653 Ingelfingen-Criesbach, Germany

declare that the product listed below complies with the safety requirements of the Pressure Equipment Directive 2014/68/EU.

Description of the pressure equipment: GEMÜ BB06
Notified body: TÜV Rheinland Industrie Service GmbH
Number: 0035
Certificate no.: 01 202 926/Q-02 0036
Conformity assessment procedure: Module H
Technical standard applied in parts: EN 1983, AD 2000

Note for products with a nominal size \leq DN 25:

The products are developed and produced according to GEMÜ process instructions and quality standards which comply with the requirements of ISO 9001 and ISO 14001.

According to Article 4, Paragraph 3 of the Pressure Equipment Directive 2014/68/EU these products must not be identified by a CE-label.

Other applied standards/ remarks:

- DIN EN ISO 5211
- DIN EN 558
- AD 2000



Joachim Brien
Head of Technical Department



GEMÜ Gebr. Müller Apparatebau GmbH & Co. KG
Fritz-Müller-Straße 6-8, 74653 Ingelfingen-Criesbach, Germany
Phone +49 (0) 7940 1230 · info@gemue.de
www.gemu-group.com

Subject to alteration

02.2024 | 88711003