

## GEMÜ B52

Motorized ball valve

EN **Operating instructions**



further information  
webcode: GW-B52



All rights including copyrights or industrial property rights are expressly reserved.

Keep the document for future reference.

© GEMÜ Gebr. Müller Apparatebau GmbH & Co. KG  
08.05.2024

## Contents

<b>1 General information</b>	<b>4</b>		
1.1 Information	4	17.1 General information regarding actuator re-	
1.2 Symbols used	4	placement	44
1.3 Definition of terms	4	17.2 Spare parts	48
1.4 Warning notes	4	<b>18 Removal from piping</b>	<b>50</b>
<b>2 Safety information</b>	<b>5</b>	<b>19 Disposal</b>	<b>50</b>
<b>3 Product description</b>	<b>5</b>	<b>20 Returns</b>	<b>50</b>
3.1 Construction	5	<b>21 EU Declaration of Incorporation according to the</b>	
3.2 Pressure-relief hole	5	<b>EC Machinery Directive 2006/42/EC, Annex II B ...</b>	<b>51</b>
3.3 Control ball	6	<b>22 Declaration of conformity according to 2014/68/</b>	
3.4 Description	6	<b>EU (Pressure Equipment Directive)</b>	<b>52</b>
3.5 Function	6	<b>23 EU Declaration of Conformity in accordance with</b>	
<b>4 GEMÜ CONEXO</b>	<b>6</b>	<b>2014/30/EU (EMC Directive)</b>	<b>53</b>
<b>5 Correct use</b>	<b>7</b>	<b>24 EU Declaration of Conformity in accordance with</b>	
<b>6 Order data</b>	<b>8</b>	<b>2014/35/EU (Low Voltage Directive)</b>	<b>54</b>
6.1 Ball valve with GEMÜ 9428, 9468 actuator ..	8		
6.2 Ball valve with J+J actuator	10		
<b>7 Ball valve technical data</b>	<b>12</b>		
7.1 Medium	12		
7.2 Temperature	12		
7.3 Pressure	12		
7.4 Product conformity	15		
7.5 Mechanical data	16		
<b>8 Technical data of actuator</b>	<b>17</b>		
8.1 GEMÜ 9428, 9468 actuators	17		
8.2 Bernard, J+J actuators	18		
<b>9 Dimensions</b>	<b>19</b>		
<b>10 Manufacturer's information</b>	<b>28</b>		
10.1 Delivery	28		
10.2 Packaging	28		
10.3 Transport	28		
10.4 Storage	28		
<b>11 Installation in piping</b>	<b>28</b>		
11.1 Preparing for installation	28		
11.2 Installation with butt weld spigots	29		
11.3 Installation with threaded connections	30		
11.4 Installation with flanged connections	31		
11.5 After the installation	31		
<b>12 Electrical connection</b>	<b>32</b>		
12.1 Connection and wiring diagram – actuator			
version 1006, 1015	32		
12.2 Connection and wiring diagram – actuator			
version 2070, 4100, 4200	36		
<b>13 Limit switches</b>	<b>39</b>		
13.1 Setting the limit switch for 1015, 2015 and			
3035	39		
13.2 Setting the limit switch for 2070, 4100,			
4200	40		
<b>14 Commissioning</b>	<b>40</b>		
<b>15 Operation</b>	<b>41</b>		
15.1 Normal operation	41		
15.2 Optical position indicator	41		
15.3 Manual override	41		
<b>16 Troubleshooting</b>	<b>43</b>		
<b>17 Inspection/maintenance</b>	<b>44</b>		

## 1 General information

### 1.1 Information

- The descriptions and instructions apply to the standard versions. For special versions not described in this document the basic information contained herein applies in combination with any additional special documentation.
- Correct installation, operation, maintenance and repair work ensure faultless operation of the product.
- Should there be any doubts or misunderstandings, the German version is the authoritative document.
- Contact us at the address on the last page for staff training information.

### 1.2 Symbols used

The following symbols are used in this document:

Symbol	Meaning
●	Tasks to be performed
▶	Response(s) to tasks
-	Lists

### 1.3 Definition of terms

#### Working medium

The medium that flows through the GEMÜ product.

#### Control medium

The medium whose increasing or decreasing pressure causes the GEMÜ product to be actuated and operated.

#### Control function

The possible actuation functions of the GEMÜ product.

### 1.4 Warning notes

Wherever possible, warning notes are organised according to the following scheme:

SIGNAL WORD	
Possible symbol for the specific danger	<p>Type and source of the danger</p> <ul style="list-style-type: none"> <li>▶ Possible consequences of non-observance.</li> <li>● Measures for avoiding danger.</li> </ul>

Warning notes are always marked with a signal word and sometimes also with a symbol for the specific danger.

The following signal words and danger levels are used:





⚠ DANGER	
	<p><b>Imminent danger!</b></p> <ul style="list-style-type: none"> <li>▶ Non-observance can cause death or severe injury.</li> </ul>

⚠ WARNING	
	<p><b>Potentially dangerous situation!</b></p> <ul style="list-style-type: none"> <li>▶ Non-observance can cause death or severe injury.</li> </ul>

⚠ CAUTION	
	<p><b>Potentially dangerous situation!</b></p> <ul style="list-style-type: none"> <li>▶ Non-observance can cause moderate to light injury.</li> </ul>

NOTICE	
	<p><b>Potentially dangerous situation!</b></p> <ul style="list-style-type: none"> <li>▶ Non-observance can cause damage to property.</li> </ul>

The following symbols for the specific dangers can be used within a warning note:

Symbol	Meaning
	Danger of explosion!
	Corrosive chemicals!
	Hot plant components!
	Risk of electric shock!

## 2 Safety information

The safety information in this document refers only to an individual product. Potentially dangerous conditions can arise in combination with other plant components, which need to be considered on the basis of a risk analysis. The operator is responsible for the production of the risk analysis and for compliance with the resulting precautionary measures and regional safety regulations.

The document contains fundamental safety information that must be observed during commissioning, operation and maintenance. Non-compliance with these instructions may cause:

- Personal hazard due to electrical, mechanical and chemical effects.
- Hazard to nearby equipment.
- Failure of important functions.
- Hazard to the environment due to the leakage of dangerous substances.

The safety information does not take into account:

- Unexpected incidents and events, which may occur during installation, operation and maintenance.
- Local safety regulations which must be adhered to by the operator and by any additional installation personnel.

### Prior to commissioning:

1. Transport and store the product correctly.
2. Do not paint the bolts and plastic parts of the product.
3. Carry out installation and commissioning using trained personnel.
4. Provide adequate training for installation and operating personnel.
5. Ensure that the contents of the document have been fully understood by the responsible personnel.
6. Define the areas of responsibility.
7. Observe the safety data sheets.
8. Observe the safety regulations for the media used.

### During operation:

9. Keep this document available at the place of use.
10. Observe the safety information.
11. Operate the product in accordance with this document.
12. Operate the product in accordance with the specifications.
13. Maintain the product correctly.
14. Do not carry out any maintenance work and repairs not described in this document without consulting the manufacturer first.

### In cases of uncertainty:

15. Consult the nearest GEMÜ sales office.

## 3 Product description

### 3.1 Construction

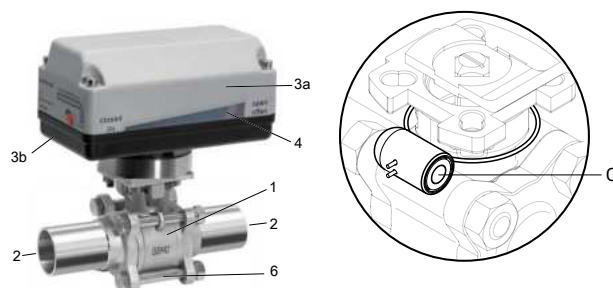

Item	Name	Materials
1	Ball valve body	1.4408 / CF8M
2	Pipe connections	1.4408 / CF8M, 1.4409 / CF3M butt weld connections
3a	Actuator housing cover Actuator version 1006,1015 Actuator version 2070 Actuator version 4100, 4200	PPO (10% glass fibre reinforced) ABS Aluminium
3b	Actuator housing base Actuator version 1006, 1015 Actuator version 2070 Actuator version 4100, 4200	PP (30% glass fibre re- inforced) ABS Aluminium
4	Optical position indicator	PP-R natural
6	Bolts	A2 70
	Seal	PTFE
C	CONEXO RFID chip	

### 3.2 Pressure-relief hole

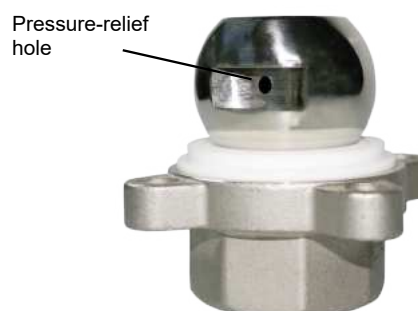

**3.3 Control ball**

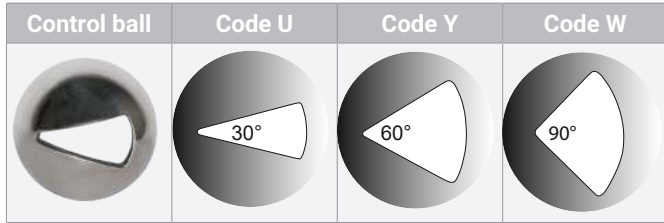

Note: The control ball cannot be retrofitted to standard 2/2-way bodies at a later date.

**3.4 Description**

The GEMÜ B52 3-piece 2/2-way metal ball valve is motorized. It has a plastic actuator housing. A manual override and an optical position indicator are integrated as standard. The seat seal is made of PTFE.

**3.5 Function**

The product is made from stainless steel and has an actuator flange and a low maintenance electric actuator with a powerful DC motor.

The reduction gear in the motor, consisting of a threaded spindle with a lever, provides the rotation through 90°.

The actuator has an optical position indicator and a manual override as standard.

**4 GEMÜ CONEXO**

The interaction of valve components that are equipped with RFID chips and an associated IT infrastructure actively increase process reliability.



Thanks to serialization, every valve and every relevant valve component such as the body, actuator or diaphragm, and even automation components, can be clearly traced and read using the CONEXO pen RFID reader. The CONEXO app, which can be installed on mobile devices, not only facilitates and improves the "installation qualification" process, but also makes the maintenance process much more transparent and easier to document. The app actively guides the maintenance technician through the maintenance schedule and directly provides him with all the information assigned to the valve, such as test reports, testing documentation and maintenance histories. The CONEXO portal acts as a central element, helping to collect, manage and process all data.

**For further information on GEMÜ CONEXO please visit:**

[www.gemu-group.com/conexo](http://www.gemu-group.com/conexo)

**Installing the RFID chip**

In the corresponding design with CONEXO, this product has an RFID chip (1) for electronic recognition. The position of the RFID chip can be seen below.

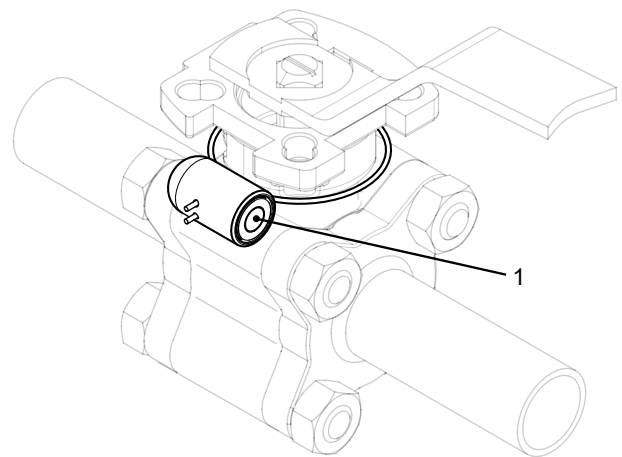

## 5 Correct use

Ball valves are used to isolate media flows.

Only clean, liquid or gaseous media must be used, and the body and seal materials used must be resistant to and suitable for this. Contaminated media and / or applications outside of the pressure and temperature data may lead to damage to the body and, in particular, to the seals on the ball valve.

The "Technical data" chapter describes the permissible pressure / temperature range for these ball valves.

### DANGER



#### Danger of explosion!

- ▶ Risk of severe injury or death
- Only versions that have been approved according to their technical data may be used in potentially explosive environments.

### WARNING

#### Improper use of the product!

- ▶ Risk of severe injury or death
- ▶ Manufacturer liability and guarantee will be void.
- Only use the product in accordance with the operating conditions specified in the contract documentation and in this document.

The product is suitable for installation in piping and for controlling a media flow. The operating conditions according to the technical data apply to the media to be controlled.

The product is controlled via a motorized actuator.

The product is not intended for use in potentially explosive areas.

The product must not be exposed to pressure fluctuations. If the product is to be used with pressure fluctuations, please contact GEMÜ.

Due to the design, in the open and closed position, a low volume of medium may be trapped within the ball or between the ball and the body.

Expansion of the medium due to temperature differences, change in state or a chemical response may lead to a high pressure build-up. In order to prevent unacceptable pressure increases, a special version with pressure-relief hole in the ball is available on request for this case.

### NOTICE

#### Build-up of lint!

- ▶ For soft-seated ball valves, due to the relative rotations of the stainless steel ball to the seat seal, slight wear of the PTFE seals must always be anticipated. Despite this, the safety of the ball valve is not affected by any potential build-up of lint and the seal materials are compliant in accordance with FDA directives.

## 6 Order data

### 6.1 Ball valve with GEMÜ 9428, 9468 actuator

The order data provide an overview of standard configurations.

Please check the availability before ordering. Other configurations available on request.

Products ordered with **bold marked ordering options** are so-called preferred series. Depending on the nominal size, these are available more quickly.

#### Order codes

1 Type	Code
Ball valve, metal, electrically operated, three-piece body, low-maintenance spindle seal and blow-out proof shaft, with anti-static unit	B52

2 DN	Code
DN 8	8
DN 10	10
DN 15	15
DN 20	20
DN 25	25
DN 32	32
DN 40	40
DN 50	50
DN 65	65
DN 80	80
DN 100	100

3 Body/ball configuration	Code
<b>2/2-way body</b>	<b>D</b>
2/2-way body, V-ball 30° (for Kv value see datasheet)	U
2/2-way body, V-ball 90° (for Kv value see datasheet)	W
2/2-way body, V-ball 60° (for Kv value see datasheet)	Y

4 Connection type	Code
<b>Spigot</b>	
Spigot EN 10357 series A/DIN 11866 series A formerly DIN 11850 series 2	17
<b>Spigot DIN EN 12627</b>	<b>19</b>
Spigot ASME BPE/DIN EN 10357 series C (from 2022 edition)/DIN 11866 series C	59
<b>Spigot ISO 1127/DIN EN 10357 series C (2014 edition)/ DIN 11866 series B</b>	<b>60</b>
<b>Threaded socket</b>	
<b>Threaded socket DIN ISO 228</b>	<b>1</b>
NPT female thread	31
<b>Flange</b>	
Flange EN 1092, PN 16, form B, face-to-face dimension FTF EN 558 series 1, ISO 5752, basic series 1	8
<b>Flange EN 1092, PN 40, form B, face-to-face dimension FTF EN 558 series 1, ISO 5752, basic series 1</b>	<b>11</b>

5 Ball valve material	Code
<b>1.4408 / CF8M (body, connection), 1.4401 / SS316 (ball, shaft)</b>	<b>37</b>
1.4408 / CF8M (body), 1.4409 / CF3M (connection), 1.4401 / SS316 (ball, shaft)	C7

6 Seal material	Code
<b>PTFE</b>	<b>5</b>

7 Voltage/Frequency	Code
12 VDC	B1
12 V 50/60 Hz	B4
24 VDC	C1
24 V 50/60 Hz	C4

8 Control module	Code
ON/OFF actuator, relay, not reversible	00
ON/OFF actuator, 2 additional potential-free limit switches, relay, not reversible	0E
ON/OFF actuator, potentiometer output, relay, not reversible	0P
ON/OFF actuator	A0
ON/OFF actuator, 2 additional potential-free limit switches, Class A (EN15714-2)	AE

9 Actuator version	Code
Actuator, motorized, operating time 4s, torque 6Nm, GEMUE, size 1 supply voltage B1, C1, B4, C4	1006
Actuator, motorized, operating time 11s, torque 15Nm, GEMUE, size 1 supply voltage B1, C1	1015
Actuator, motorized, operating time 15s, torque 70Nm, GEMUE, size 2 supply voltage C1	2070
Actuator, motorized, operating time 20s, torque 100Nm, GEMUE, size 4 supply voltage C1	4100
Actuator, motorized, operating time 16s, torque 200Nm, GEMUE, size 4 supply voltage C1	4200

10 Type of design	Code
Standard	
Media wetted area cleaned to ensure suitability for paint applications, parts sealed in plastic bag	0101



10 Type of design	Code
Valve free of oil and grease, media wetted area cleaned and packed in PE bag	0107
Thermal separation between actuator and valve body via mounting kit	5222
Thermal separation between actuator and valve body via mounting kit, mounting kit and mounting parts made from stainless steel	5227
K-no. 0101, K-no. 5227, 0101 - Media wetted area cleaned to ensure suitability for paint applications, 5227 - Thermal separation via mounting kit	5238
K-no. 0107, K-no. 5227, 0107 - Media wetted area cleaned to ensure suitability for paint applications, 5227 - Thermal separation via mounting kit	5239

11 Special version	Code
Without	
Special version for oxygen maximum medium temperature: 60 °C, Media wetted materials cleaned, and grease and seal with BAM testing	O
ASME B31.3	P

12 CONEXO	Code
Without	
Integrated RFID chip for electronic identification and traceability	C

### Order example

Ordering option	Code	Description
1 Type	B52	Ball valve, metal, electrically operated, three-piece body, low-maintenance spindle seal and blow-out proof shaft, with anti-static unit
2 DN	15	DN 15
3 Body/ball configuration	D	2/2-way body
4 Connection type	1	Threaded socket DIN ISO 228
5 Ball valve material	37	1.4408 / CF8M (body, connection), 1.4401 / SS316 (ball, shaft)
6 Seal material	5	PTFE
7 Voltage/Frequency	C1	24 VDC
8 Control module	A0	ON/OFF actuator
9 Actuator version	1015	Actuator, motorized, operating time 11s, torque 15Nm, GEMUE, size 1 supply voltage B1, C1
10 Type of design		Standard
11 Special version		Without
12 CONEXO		Without

## 6.2 Ball valve with J+J actuator

The order data provide an overview of standard configurations.

Please check the availability before ordering. Other configurations available on request.

Products ordered with **bold marked ordering options** are so-called preferred series. Depending on the nominal size, these are available more quickly.

### Order codes

1 Type	Code
Ball valve, metal, electrically operated, three-piece body, low-maintenance spindle seal and blow-out proof shaft, with anti-static unit	B52

2 DN	Code
DN 8	8
DN 10	10
DN 15	15
DN 20	20
DN 25	25
DN 32	32
DN 40	40
DN 50	50
DN 65	65
DN 80	80
DN 100	100

3 Body/ball configuration	Code
<b>2/2-way body</b>	<b>D</b>
2/2-way body, V-ball 30° (for Kv value see datasheet)	U
2/2-way body, V-ball 90° (for Kv value see datasheet)	W
2/2-way body, V-ball 60° (for Kv value see datasheet)	Y

4 Connection type	Code
<b>Spigot</b>	
Spigot EN 10357 series A/DIN 11866 series A formerly DIN 11850 series 2	17
<b>Spigot DIN EN 12627</b>	<b>19</b>
Spigot ASME BPE/DIN EN 10357 series C (from 2022 edition)/DIN 11866 series C	59
<b>Spigot ISO 1127/DIN EN 10357 series C (2014 edition)/DIN 11866 series B</b>	<b>60</b>
<b>Threaded socket</b>	
<b>Threaded socket DIN ISO 228</b>	<b>1</b>
NPT female thread	31
<b>Flange</b>	
Flange EN 1092, PN 16, form B, face-to-face dimension FTF EN 558 series 1, ISO 5752, basic series 1	8
<b>Flange EN 1092, PN 40, form B, face-to-face dimension FTF EN 558 series 1, ISO 5752, basic series 1</b>	<b>11</b>

5 Ball valve material	Code
<b>1.4408 / CF8M (body, connection), 1.4401 / SS316 (ball, shaft)</b>	<b>37</b>

5 Ball valve material	Code
1.4408 / CF8M (body), 1.4409 / CF3M (connection), 1.4401 / SS316 (ball, shaft)	C7

6 Seal material	Code
<b>PTFE</b>	<b>5</b>

7 Voltage/Frequency	Code
12 VDC	B1
24 - 240 V AC 24 - 135 V DC for model 20, 35, 55, 85, 140, 300	U5

8 Control module	Code
ON/OFF actuator, 3-position actuator, additional potential-free limit switches	A3
ON/OFF actuator, 2 additional potential-free limit switches, Class A (EN15714-2)	AE
ON/OFF actuator, 2 additional potential-free limit switches, BSR battery pack (NC)	AE1
ON/OFF actuator, 2 additional potential-free limit switches, BSR battery pack (NO)	AE2
ON/OFF actuator, potentiometer output, Class A (EN15714-2)	AP
ON/OFF actuator, 2 additional potential-free limit switches, potentiometer output 5 kOhm, Failsafe battery pack (NC), preferred direction adjustable	AP1
Control actuator, external set value 0-10 VDC	E1
Control actuator, external set value 0/4-20 mA	E2
Positioner DPS, external set value 0-10V, BSR battery pack (NC)	E11
Positioner DPS, external set value 4-20mA, BSR battery pack (NO)	E22

9 Actuator version	Code
Actuator, motorized, operating time 9s, torque 20Nm, J+J, type J4 heating, IP67	J4C20
Actuator, motorized, operating time 9s, torque 35Nm, J+J, type J4 heating, IP67	J4C35
Actuator, motorized, operating time 13s, torque 55Nm, J+J, type J4 heating, IP67	J4C55
Actuator, motorized, operating time 29s, torque 85Nm, J+J, type J4 heating, IP67	J4C85

9 Actuator version	Code
Actuator, motorized, operating time 34s, torque 140Nm, J+J, type J4 heating, IP67	J4C14

10 Type of design	Code
Standard	
Media wetted area cleaned to ensure suitability for paint applications, parts sealed in plastic bag	0101
Valve free of oil and grease, media wetted area cleaned and packed in PE bag	0107
Thermal separation between actuator and valve body via mounting kit	5222
Thermal separation between actuator and valve body via mounting kit, mounting kit and mounting parts made from stainless steel	5227

10 Type of design	Code
K-no. 0101, K-no. 5227, 0101 - Media wetted area cleaned to ensure suitability for paint applications, 5227 - Thermal separation via mounting kit	5238
K-no. 0107, K-no. 5227, 0107 - Media wetted area cleaned to ensure suitability for paint applications, 5227 - Thermal separation via mounting kit	5239

11 Special version	Code
Without	
Special version for oxygen maximum medium temperature: 60 °C, Media wetted materials cleaned, and grease and seal with BAM testing	O
ASME B31.3	P

12 CONEXO	Code
Without	
Integrated RFID chip for electronic identification and traceability	C

### Order example

Ordering option	Code	Description
1 Type	B52	Ball valve, metal, electrically operated, three-piece body, low-maintenance spindle seal and blow-out proof shaft, with anti-static unit
2 DN	15	DN 15
3 Body/ball configuration	D	2/2-way body
4 Connection type	1	Threaded socket DIN ISO 228
5 Ball valve material	37	1.4408 / CF8M (body, connection), 1.4401 / SS316 (ball, shaft)
6 Seal material	5	PTFE
7 Voltage/Frequency	B1	12 VDC
8 Control module	AE	ON/OFF actuator, 2 additional potential-free limit switches, Class A (EN15714-2)
9 Actuator version	J4C20	Actuator, motorized, operating time 9s, torque 20Nm, J+J, type J4 heating, IP67
10 Type of design		Standard
11 CONEXO		Without
12 Special version		Without

## 7 Ball valve technical data

### 7.1 Medium

**Working medium:** Corrosive, inert, gaseous and liquid media and steam which have no negative impact on the physical and chemical properties of the body and seal material.

### 7.2 Temperature

**Media temperature:** Connection code 17, 19, 59, 60: -10 – 180 °C  
 Connection code 1, 31, 8, 11: -20 – 180 °C  
 For media temperatures > 100 °C, we recommend using a mounting kit with adapter between the ball valve and the actuator.

**Ambient temperature:** -20 – 60 °C

**Storage temperature:** 5 – 40 °C

### 7.3 Pressure

**Operating pressure:** 0 – 63 bar

**Vacuum:** Can be used up to a vacuum of 50 mbar (absolute)  
 These values apply to room temperature and air. The values may deviate for other media and other temperatures.

**Pressure/temperature diagram:**

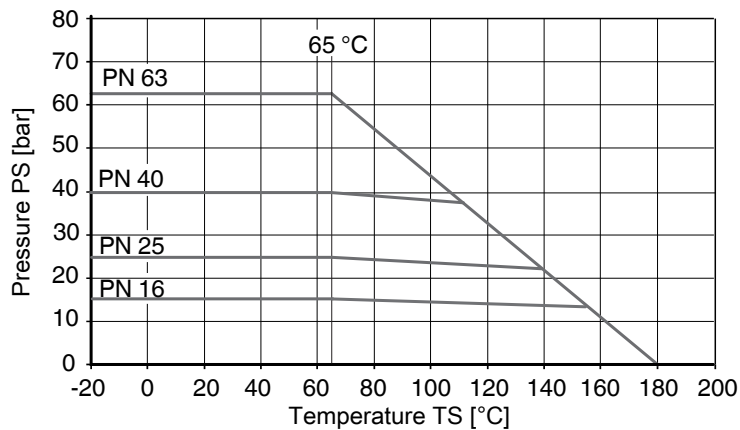

**Note media temperature**

Pressure/temperature data in accordance with diagram refers to static operating conditions. Strongly fluctuating or fast-changing parameters can lead to a reduction of the service life. Special applications must be talked through with your technical contact person in advance.

**Leakage rate:** Leakage rate according to ANSI FCI70 – B16.104  
 Leakage rate according to EN12266, 6 bar air, leakage rate A

## Kv values:

## Standard ball (code D)

DN	NPS	Cv values
8	1/4"	8.0
10	3/8"	8.0
15	1/2"	17.0
20	3/4"	34.0
25	1"	60.0
32	1¼"	94.0
40	1½"	213.0
50	2"	366.0
65	2½"	595.0
80	3"	935.0
100	4"	1700.0

Cv values in m<sup>3</sup>/h

## Diagrammatic view

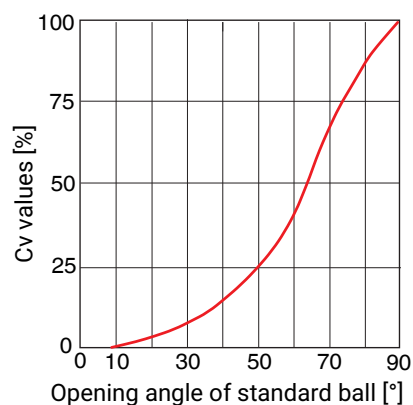

## V-ball 30° (code U)

DN	NPS	Opening angle										
		0	15%	20%	30%	40%	50%	60%	70%	80%	90%	100%
15	1/2"	0	0.085	0.085	0.170	0.255	0.425	0.680	0.935	1.360	1.870	2.210
20	3/4"	0	0.085	0.170	0.425	0.595	0.935	1.530	2.040	2.805	3.825	4.590
25	1"	0	0.085	0.255	0.680	1.105	1.955	2.975	4.335	5.961	8.128	8.500
32	1¼"	0	0.170	0.340	0.935	1.700	3.145	4.675	6.800	8.500	11.050	12.750
40	1½"	0	0.255	0.510	1.360	2.550	4.250	6.375	9.350	11.900	14.450	17.000
50	2"	0	0.340	1.020	3.230	5.100	8.500	12.75	19.550	26.350	36.550	51.000
65	2½"	0	0.340	0.850	3.400	6.800	10.200	15.300	23.800	31.450	52.70	63.750
80	3"	0	0.425	1.020	3.400	6.800	11.900	19.550	28.050	39.100	55.250	69.700
100	4"	0	0.510	1.700	5.100	12.750	24.650	40.800	60.350	85.000	110.50	135.20

Cv values in m<sup>3</sup>/h

**Kv values:****V-ball 60° (code Y)**

DN	NPS	Opening angle										
		0	15%	20%	30%	40%	50%	60%	70%	80%	90%	100%
15	1/2"	0	0.085	0.085	0.255	0.425	0.765	1.190	1.700	2.805	3.740	5.100
20	3/4"	0	0.085	0.170	0.595	0.850	1.445	2.380	3.400	5.525	7.650	10.200
25	1"	0	0.170	0.340	0.935	1.530	2.890	4.505	6.715	10.46	13.010	17.850
32	1¼"	0	0.170	0.510	1.530	2.550	4.675	8.075	10.880	16.15	22.100	33.150
40	1½"	0	0.340	0.680	2.125	3.400	6.800	11.050	16.150	22.95	34.000	44.200
50	2"	0	0.340	1.275	3.910	7.650	14.030	22.950	33.150	46.75	70.550	93.500
65	2½"	0	0.340	1.275	4.250	8.500	17.850	28.900	45.050	63.75	87.550	127.50
80	3"	0	0.425	2.125	5.100	11.900	21.250	34.000	55.250	77.35	108.80	140.30
100	4"	0	0.595	2.550	9.350	21.250	34.000	50.150	76.500	119.9	180.20	302.60

Cv values in m³/h

**V-ball 90° (code W)**

DN	NPS	Opening angle										
		0	15%	20%	30%	40%	50%	60%	70%	80%	90%	100%
15	1/2"	0	0.085	0.170	0.340	0.510	0.765	1.275	1.870	3.230	4.590	5.865
20	3/4"	0	0.170	0.340	0.680	1.020	1.700	2.635	3.910	6.800	9.605	11.900
25	1"	0	0.170	0.510	1.530	2.890	4.335	6.885	9.690	13.600	17.850	24.650
32	1¼"	0	0.255	0.680	1.700	4.250	6.800	11.900	16.150	23.800	33.150	46.750
40	1½"	0	0.425	0.765	2.975	5.950	11.050	17.000	26.350	35.700	53.550	66.300
50	2"	0	0.595	1.700	5.100	10.200	18.700	29.750	38.250	59.500	89.250	114.80
65	2½"	0	0.425	1.445	5.950	11.900	23.800	40.800	59.500	90.100	136.00	185.30
80	3"	0	0.595	2.975	6.800	15.300	29.750	51.000	76.500	114.80	174.30	263.50
100	4"	0	0.850	2.975	13.600	34.000	63.750	106.30	161.50	250.80	375.70	569.50

Cv values in m³/h

**Pressure rating:**

DN	Spigot				Threaded socket		Flange	
	Connection type code <sup>1)</sup>							
	17	19	59	60	1	31	8	11
<b>8</b>	-	PN63	-	PN63	PN63	PN63	-	-
<b>10</b>	PN63	PN63	-	PN63	PN63	PN63	-	-
<b>15</b>	PN63	PN63	PN63	PN63	PN63	PN63	-	PN40
<b>20</b>	PN63	PN63	PN63	PN63	PN63	PN63	-	PN40
<b>25</b>	PN63	PN63	PN63	PN63	PN63	PN63	-	PN40
<b>32</b>	PN63	PN63	-	PN63	PN63	PN63	-	PN40
<b>40</b>	PN63	PN63	PN63	PN63	PN63	PN63	-	PN40
<b>50</b>	PN63	PN63	PN63	PN63	PN63	PN63	-	PN40
<b>65</b>	PN40	PN40	PN40	PN40	PN40	PN40	PN16	PN40*
<b>80</b>	PN40	PN40	PN40	PN40	PN40	PN40	PN16	-
<b>100</b>	PN25	PN25	PN25	PN25	PN25	PN25	PN16	-

\* on request

1) **Connection type**

Code 1: Threaded socket DIN ISO 228

Code 31: NPT female thread

Code 8: Flange EN 1092, PN 16, form B, face-to-face dimension FTF EN 558 series 1, ISO 5752, basic series 1

Code 11: Flange EN 1092, PN 40, form B, face-to-face dimension FTF EN 558 series 1, ISO 5752, basic series 1

Code 17: Spigot EN 10357 series A/DIN 11866 series A formerly DIN 11850 series 2

Code 19: Spigot DIN EN 12627

Code 59: Spigot ASME BPE/DIN EN 10357 series C (from 2022 edition)/DIN 11866 series C

Code 60: Spigot ISO 1127/DIN EN 10357 series C (2014 edition)/DIN 11866 series B

**7.4 Product conformity****Pressure equipment standards:**ASME GEMÜ B31.3 (DN 15 – 100)  
2014/68/EU**Food:**FDA  
Regulation (EC) No. 10/2011  
Regulation (EC) No. 1935/2006**Explosion protection:**

ATEX (2014/34/EU), order code Special version X

**ATEX marking:**

The ATEX marking of the product depends on the respective product configuration with valve body and actuator. It can be found in the product-specific ATEX documentation and the ATEX type plate.

**Oxygen:**

BAM compliant, the product is suitable for application with oxygen

**7.5 Mechanical data****Torques:**

DN	NPS	Breakaway torque
8	1/4"	6.0
10	3/8"	6.0
15	1/2"	6.0
20	3/4"	10.0
25	1"	11.0
32	1¼"	17.0
40	1½"	28.0
50	2"	53.0
65	2½"	76.0
80	3"	89.0
100	4"	138.0

Torques in Nm

A safety factor of 1.2 is included

With dry, non-lubricating media the breakaway torque may be increased.

Valid for clean, non-particulate and oil-free media (water, alcohol, etc.), gas or saturated steam (clean and wet).  
PTFE seal.

**Weight:****Ball valve**

DN	NPS	Threaded connection, spigot	Flange
8	1/4"	0.55	1.15
10	3/8"	0.55	1.15
15	1/2"	0.6	1.35
20	3/4"	0.7	1.45
25	1"	0.8	1.8
32	1¼"	1.2	2.4
40	1½"	2.3	3.5
50	2"	3.5	4.9
65	2½"	6.9	9.3
80	3"	11.7	14.7
100	4"	19.3	22.3

Weights in kg



## 8 Technical data of actuator

### 8.1 GEMÜ 9428, 9468 actuators

#### 8.1.1 Mechanical data

Weight:

#### GEMÜ 9428

Supply voltage 12 V / 24 V:	1.0 kg
-----------------------------	--------

#### Actuator type 9468

Actuator version 2070:	4.6 kg
Actuator version 4100, 4200:	11.6 kg

#### 8.1.2 Product compliance

Machinery Directive: 2006/42/EC

EMC Directive: 2014/30/EU

Low Voltage Directive: 2014/35/EU

RoHS Directive: 2011/65/EU (GEMÜ 9428)

#### 8.1.3 Electrical data

Rated voltage: 12 V / 24 V AC or DC ( $\pm 10\%$ )

Rated frequency: 50/60 Hz (at AC rated voltage)

Electrical protection class: I (DIN EN 61140)

Power consumption:

Actuator version (code)	Control module (code)	12 V DC (code B1)	12 V AC (code B4)	24 V DC (code C1)	24 V AC (code C4)
1006, 3006	A0, AE	30.0	30.0	30.0	30.0
1015, 3015	A0, AE	30.0	-	30.0	-
2070	00, 0E, 0P	-	-	63.0	-
4100	00, 0E, 0P	-	-	105.0	-
4200	00, 0E, 0P	-	-	90.0	-

Power consumption in W

Current consumption:

Actuator version (code)	Control module (code)	12 V DC (code B1)	12 V AC (code B4)	24 V DC (code C1)	24 V AC (code C4)
1006, 3006	A0, AE	2.2	2.0	1.20	1.5
1015, 3015	A0, AE	2.2	-	1.20	-
2070	00, 0E, 0P	-	-	2.60	-
4100	00, 0E, 0P	-	-	4.40	-
4200	00, 0E, 0P	-	-	3.60	-

Current data in A

**Max. switching current:**

Actuator version (code)	Control module (code)	12 V DC (code B1)	12 V AC (code B4)	24 V DC (code C1)	24 V AC (code C4)
<b>1006, 3006</b>	<b>A0, AE</b>	6.3	2.4	4.0	1.8
<b>1015, 3015</b>	<b>A0, AE</b>	9.2	-	3.8	-
<b>2070</b>	<b>00, 0E, 0P</b>	-	-	14.0	
<b>4100</b>	<b>00, 0E, 0P</b>	-	-	35.0	-
<b>4200</b>	<b>00, 0E, 0P</b>	-	-	35.0	

Current data in A

**Input signal:**24 V DC, 24 V AC, 120 V AC, 230 V AC  
dependent on rated voltage**Duty cycle:**

Continuous duty

**Electrical protection:****GEMÜ 9428**

Motor protective system by customer

**GEMÜ 9468**

Internal for functional module 0x

Actuator version 2070: MT 6.3 A

Actuator version 4100, 4200: MT 10.0 A

Motor protective system by customer, see "Recommended motor protection"

**Recommended motor protection:****GEMÜ 9428**

Voltage	12 V DC	24 V DC
<b>Motor protection switch type</b>	Siemens 3RV 1011-1CA10	Siemens 3RV 1011-1BA10
<b>Set current</b>	2.20	1.70

Current data in A

**GEMÜ 9468**

Motor protection switch Siemens 3RV 1011-1FA10

type:

Set current: 4.0 A

**8.2 Bernard, J+J actuators**

Note: For technical data see manufacturer's original datasheets

## 9 Dimensions

### 9.1 Actuator dimensions

#### 9.1.1 GEMÜ 9428, 9468 actuators

Note on actuator mounting:

Standard mounting orientation – actuator positioned in-line with piping

Only with flanged connections the actuator is mounted across the piping

##### 9.1.1.1 Actuator version 1006, 1015

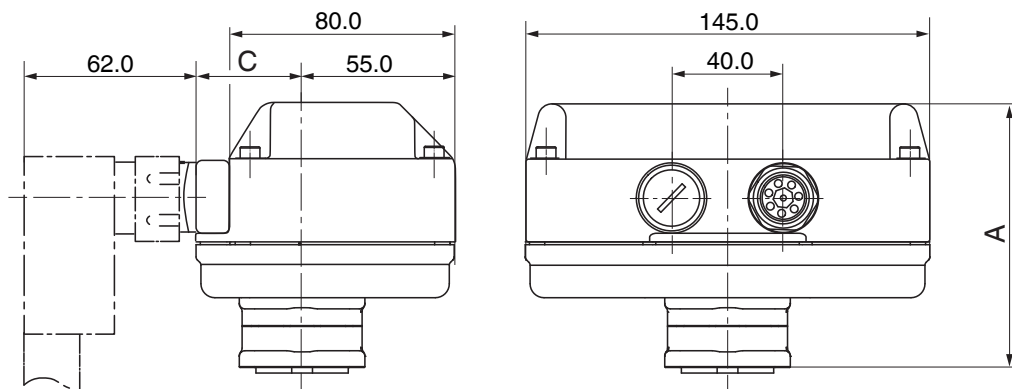

Actuator version	A	C
<b>1006, 1015</b>	94.0	49.0

Dimensions in mm

##### 9.1.1.2 Actuator version 2070

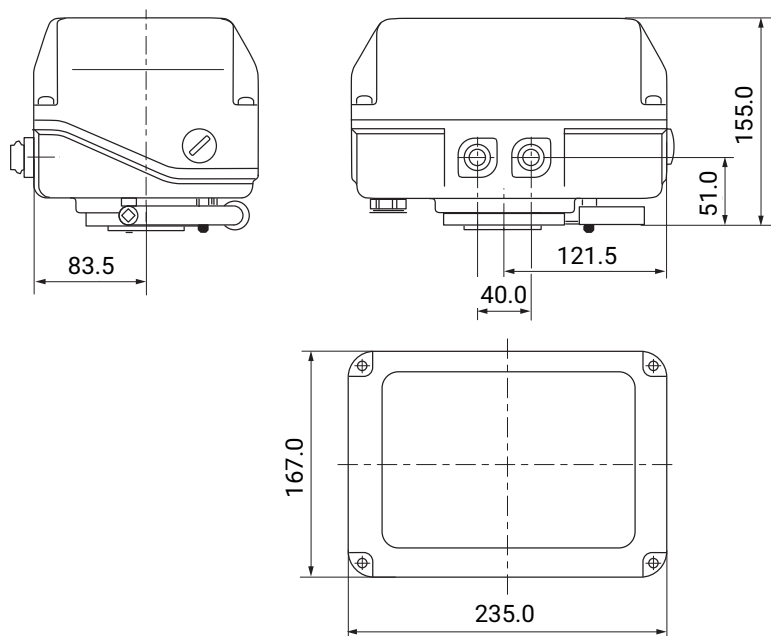

Dimensions in mm

**9.1.1.3 Actuator version 4100, 4200**

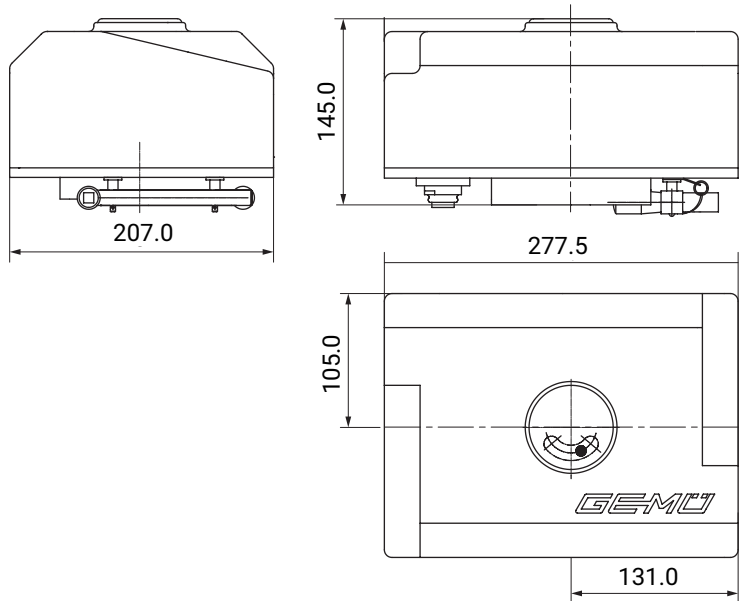

Dimensions in mm

**9.1.2 Bernard, AUMA, J+J actuators**

For more detailed information on third-party actuators, refer to the manufacturers' documentation

## 9.2 Ball valve

### 9.2.1 Actuator flange

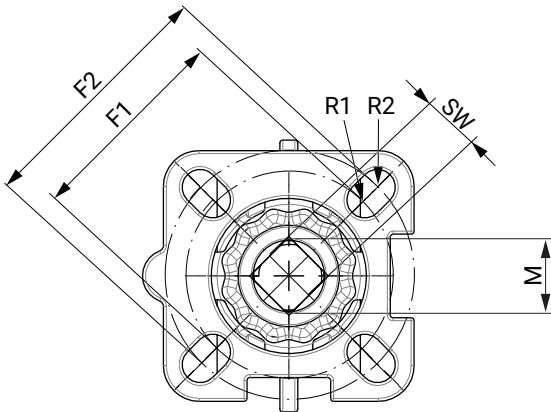

DN	G	F1	ISO 5211	R1	F2	ISO 5211	R2	SW	M
8	1/4"	36.0	F03	3.0	42.0	F04	3.0	9.0	M12
10	3/8"	36.0	F03	3.0	42.0	F04	3.0	9.0	M12
15	1/2"	36.0	F03	3.0	42.0	F04	3.0	9.0	M12
20	3/4"	36.0	F03	3.0	42.0	F04	3.0	9.0	M12
25	1"	42.0	F04	3.0	50.0	F05	3.5	11.0	M14
32	1 1/4"	42.0	F04	3.0	50.0	F05	3.5	11.0	M14
40	1 1/2"	50.0	F05	3.5	70.0	F07	4.5	14.0	M18
50	2"	50.0	F05	3.5	70.0	F07	4.5	14.0	M18
65	2 1/2"	50.0	F05	3.5	70.0	F07	4.5	14.0	M18
80	3"	70.0	F07	5.0	102.0	F10	6.0	17.0	M22
100	4"	70.0	F07	5.0	102.0	F10	6.0	17.0	M22

Dimensions in mm

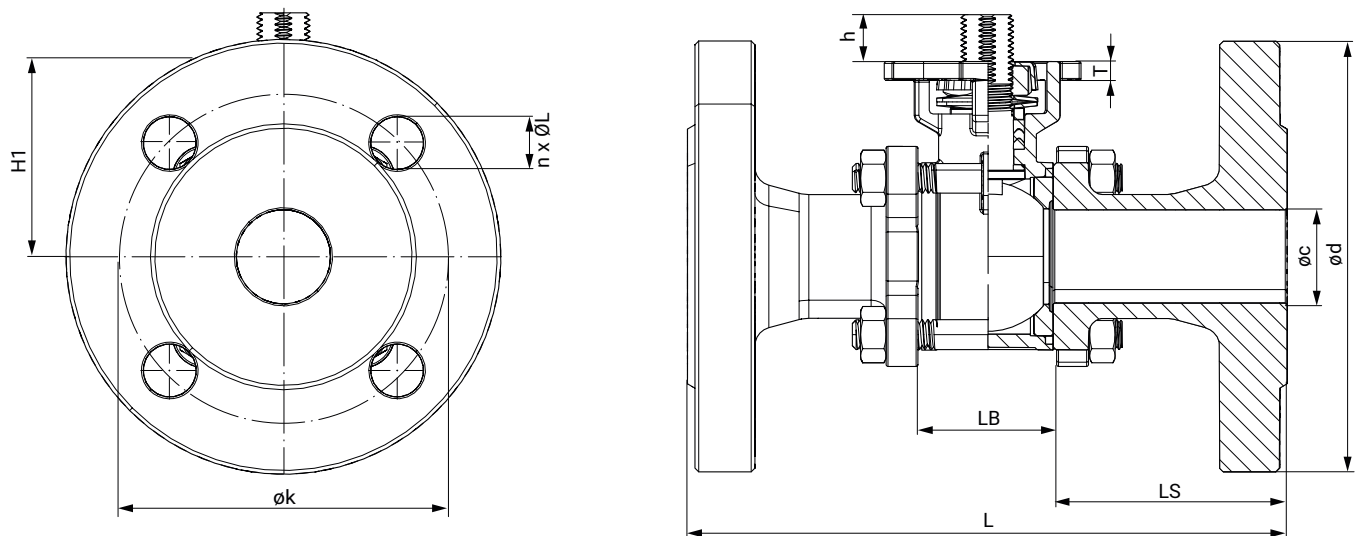
**9.2.2 Body dimensions****9.2.2.1 Flange (connection code 8, 11)**

DN	Connec- tion code	$\varnothing c$	$\varnothing d$	$\varnothing k$	h	L	LB	LS	H1	T	n x $\varnothing L$
15	11	15.0	95.0	65.0	9.0	130.0	24.0	53.0	40.5	5.5	4 x 14.0
20	11	20.0	105.0	75.0	10.5	150.0	29.0	60.5	45.0	5.5	4 x 14.0
25	11	25.0	115.0	85.0	12.5	160.0	35.0	62.5	52.0	5.0	4 x 14.0
32	11	32.0	140.0	100.0	12.5	180.0	44.0	68.0	57.0	6.5	4 x 18.0
40	11	38.0	150.0	110.0	16.0	200.0	53.0	73.5	69.0	7.5	4 x 18.0
50	11	49.0	165.0	125.0	16.0	230.0	65.0	82.5	77.0	8.5	4 x 18.0
65	8	65.0	185.0	145.0	15.0	290.0	81.0	104.5	90.0	8.5	4 x 18.0
80	8	76.0	200.0	160.0	18.0	310.0	96.0	107.0	108.0	10.0	8 x 18.0
100	8	100.0	220.0	180.0	18.0	350.0	124.0	113.0	123.0	10.0	8 x 18.0

Dimensions in mm  
n = number of bolts

## 9.2.2.2 Threaded socket (connection code 1, 31)

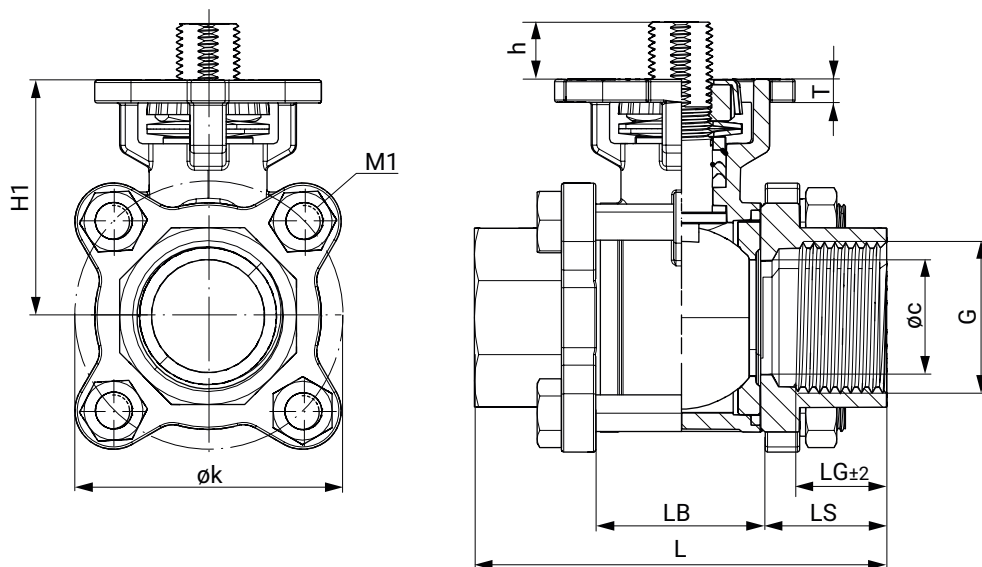

DN	G	øc	øk	h	LG	L	LB	LS	H1	M1	T
8	1/4"	10.0	46.0	9.0	12.0	55.0	24.0	15.5	40.5	M8	12.0
10	3/8"	12.0	46.0	9.0	12.0	60.0	24.0	18.0	40.5	M8	14.0
15	1/2"	15.0	46.0	9.0	16.0	75.0	24.0	25.5	40.5	M8	16.0
20	3/4"	20.0	51.0	10.5	16.0	80.0	29.0	25.5	45.0	M8	16.0
25	1"	25.0	61.0	12.5	17.0	90.0	35.0	27.5	52.0	M8	17.0
32	1¼"	32.0	73.0	12.5	20.0	110.0	44.0	33.0	57.0	M10	20.0
40	1½"	38.0	83.0	16.0	22.0	120.0	53.0	33.5	69.0	M10	22.0
50	2"	49.0	101.0	16.0	24.0	140.0	65.0	37.5	77.0	M12	24.0
65	2½"	64.0	130.0	15.0	28.0	185.0	81.0	52.0	90.0	M12	28.0
80	3"	76.0	155.0	18.0	32.0	205.0	96.0	54.5	108.0	M14	32.0
100	4"	100.0	187.0	18.0	40.0	240.0	124.0	58.0	123.0	M14	40.0

Dimensions in mm

## 9.2.2.3 Spigot EN 10357 series A (connection code 17)

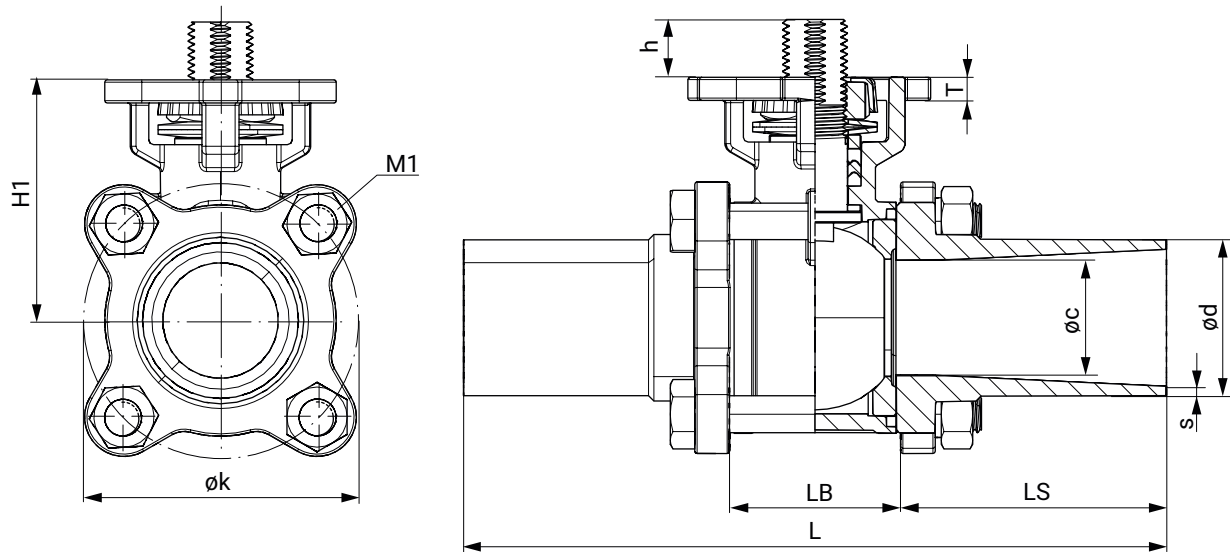

DN	øc	ød	h	øk	s	L	LB	LS	H1	M1	SW	T
10	10.0	13.0	9.0	46.0	1.5	120.0	24.0	48.0	40.5	M8	18.0	5.5
15	15.0	19.0	9.0	46.0	1.5	140.2	24.0	58.0	40.5	M8	18.0	5.5
20	20.0	23.0	10.5	51.0	1.5	140.0	29.0	55.5	45.0	M8	18.0	5.5
25	25.0	29.0	12.5	61.0	1.5	152.2	35.0	58.5	52.0	M8	21.0	5.0
32	32.0	35.0	12.5	73.0	1.5	165.1	44.0	60.5	57.0	M10	21.0	6.5
40	38.0	41.0	16.0	83.0	1.5	190.4	53.0	68.5	69.0	M10	27.0	7.5
50	50.0	53.0	16.0	101.0	1.5	203.0	65.0	69.0	77.0	M12	27.0	8.5
65	65.0	70.0	15.0	130.0	2.0	254.0	81.0	86.5	90.0	M12	27.0	8.5
80	80.0	85.0	18.0	155.0	2.0	280.2	96.0	92.0	108.0	M14	-	10.0
100	100.0	104.0	18.0	187.0	2.0	317.0	124.0	96.5	123.0	M14	-	10.0

Dimensions in mm



## 9.2.2.4 Spigot DIN EN 12627 (connection code 19)

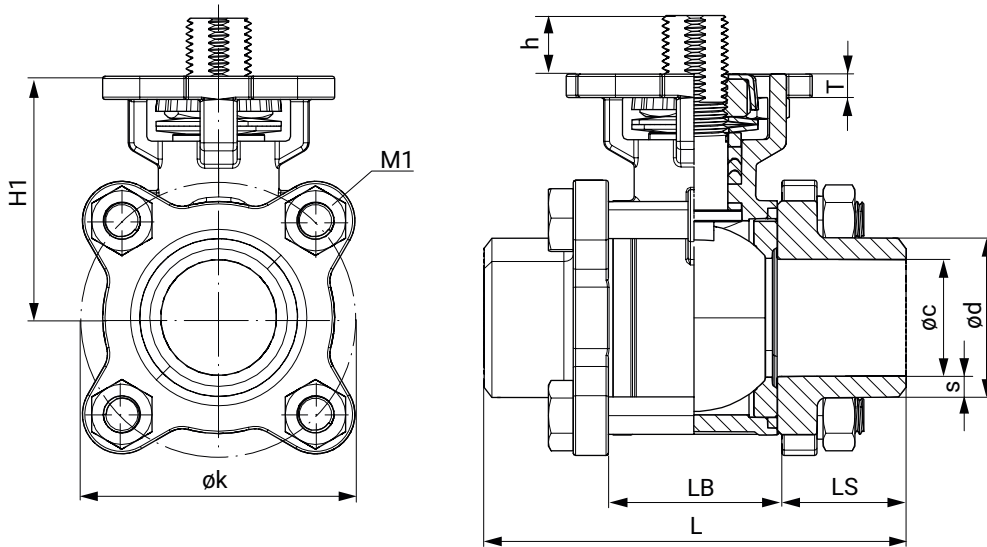

DN	øc	ød	øk	h	s	L	LB	LS	H1	M1	T
8	11.6	16.2	46.0	9.0	2.30	60.0	24.0	18.0	40.5	M8	5.5
10	12.7	17.5	46.0	9.0	2.40	60.0	24.0	18.0	40.5	M8	5.5
15	15.0	21.7	46.0	9.0	3.35	75.0	24.0	25.5	40.5	M8	5.5
20	20.0	27.2	51.0	10.5	3.60	80.0	29.0	25.5	45.0	M8	5.5
25	25.0	34.0	61.0	12.5	4.50	90.0	35.0	27.5	52.0	M8	5.0
32	32.0	42.7	73.0	12.5	5.35	110.0	44.0	33.0	57.0	M10	6.5
40	38.0	48.6	83.0	16.0	5.30	120.0	53.0	33.5	69.0	M10	7.5
50	50.0	60.5	101.0	16.0	5.25	140.0	65.0	37.5	77.0	M12	8.5
65	63.0	76.3	130.0	15.0	6.65	185.3	81.0	52.2	90.0	M12	8.5
80	76.0	89.0	155.0	18.0	6.50	205.0	96.0	54.5	108.0	M14	10.0
100	100.0	116.0	187.0	18.0	8.00	240.0	124.0	58.0	123.0	M14	10.0

Dimensions in mm

## 9.2.2.5 Spigot ASME (connection code 59)

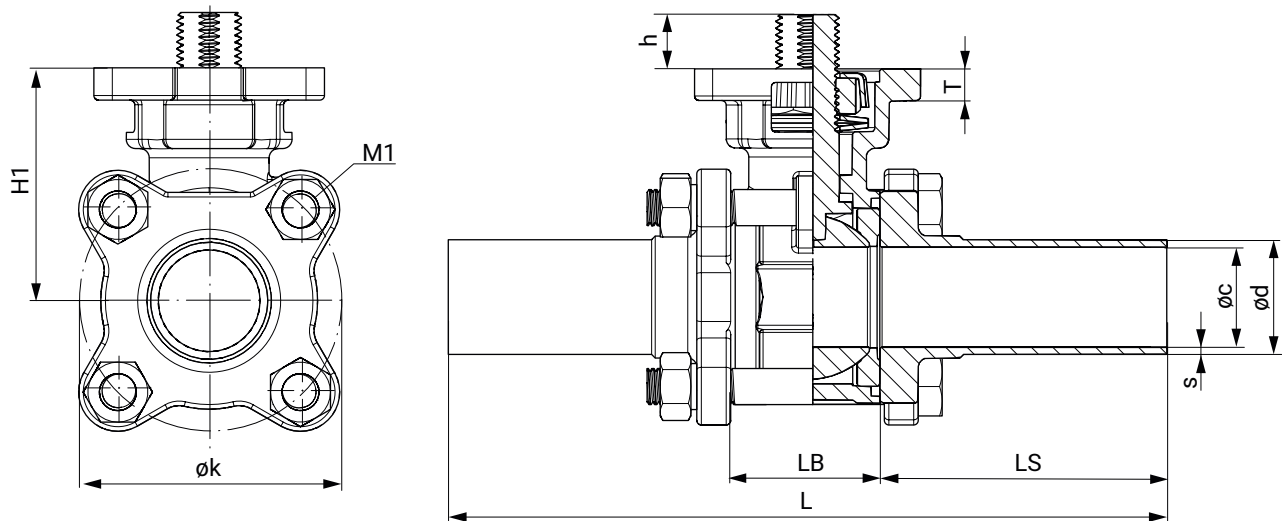

DN	$\phi c$	$\phi d$	h	$\phi k$	s	L	LB	LS	H1	M1	T
15	9.4	12.7	8.5	46.0	1.65	140.0	25.0	57.5	40.5	M8	5.0
20	15.7	19.0	10.5	47.0	1.65	146.0	28.0	59.0	43.5	M8	5.0
25	22.1	25.4	12.0	56.0	1.65	159.0	32.0	63.5	50.5	M8	7.0
40	34.8	38.1	14.5	79.0	1.65	191.0	48.0	71.5	67.5	M10	8.0
50	47.5	50.8	14.5	98.5	1.65	216.0	62.0	77.0	75.5	M12	8.0
65	60.2	63.5	14.5	126.0	1.65	248.0	80.0	84.0	88.0	M12	8.0
80	72.9	76.2	17.5	146.0	1.65	267.0	90.0	88.5	105.0	M14	10.0
100	97.4	101.6	17.5	180.0	2.15	318.0	118.0	100.0	120.0	M14	10.0

Dimensions in mm

## 9.2.2.6 Spigot ISO (connection code 60)

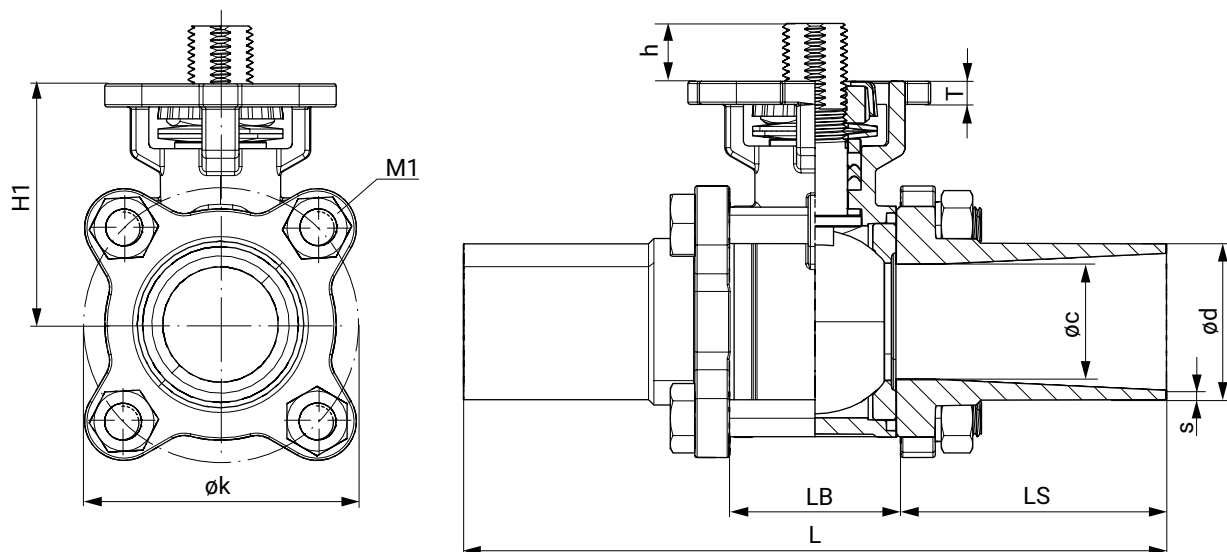

DN	øc	ød	h	øk	s	L	LB	LS	H1	M1	T
8	10.3	13.5	9.0	46.0	1.6	120.0	24.0	48.0	40.5	M8	5.5
10	12.0	17.2	9.0	46.0	1.6	120.0	24.0	48.0	40.5	M8	5.5
15	15.0	21.3	9.0	46.0	1.6	140.2	24.0	58.0	40.5	M8	5.5
20	20.0	26.9	10.5	51.0	1.6	140.0	29.0	55.5	45.0	M8	5.5
25	25.0	33.7	12.5	59.0	2.0	152.2	35.0	58.5	52.0	M8	5.0
32	32.0	42.4	12.5	73.0	2.0	165.1	44.0	60.5	57.0	M10	6.5
40	38.0	48.3	16.0	83.0	2.0	190.4	53.0	68.5	69.0	M10	7.5
50	49.0	60.3	16.0	103.0	2.0	203.0	65.0	69.0	77.0	M12	8.5
65	64.0	76.1	15.0	130.0	2.0	254.0	81.0	86.5	90.0	M12	8.5
80	76.0	88.9	18.0	155.0	2.3	280.2	96.0	92.0	108.0	M14	10.0
100	100.0	114.3	18.0	187.0	2.3	317.0	124.0	96.5	123.0	M14	10.0

Dimensions in mm

## 10 Manufacturer's information

### 10.1 Delivery

- Check that all parts are present and check for any damage immediately upon receipt.

The product's performance is tested at the factory. The scope of delivery is apparent from the dispatch documents and the design from the order number.

### 10.2 Packaging

The product is packaged in a cardboard box which can be recycled as paper.

### 10.3 Transport

1. Only transport the product by suitable means. Do not drop. Handle carefully.
2. After the installation dispose of transport packaging material according to relevant local or national disposal regulations / environmental protection laws.

### 10.4 Storage

1. Store the product free from dust and moisture in its original packaging.
2. Avoid UV rays and direct sunlight.
3. Do not exceed the maximum storage temperature (see chapter "Technical data").
4. Do not store solvents, chemicals, acids, fuels or similar fluids in the same room as GEMÜ products and their spare parts.
5. Store the ball valves in the "open" position.

## 11 Installation in piping

### 11.1 Preparing for installation

#### **WARNING**

##### **The equipment is subject to pressure!**

- ▶ Risk of severe injury or death
- Depressurize the plant.
- Completely drain the plant.

#### **WARNING**



##### **Corrosive chemicals!**

- ▶ Risk of caustic burns
- Wear appropriate protective gear.
- Completely drain the plant.

#### **CAUTION**



##### **Hot plant components!**

- ▶ Risk of burns
- Only work on plant that has cooled down.

#### **CAUTION**

##### **Exceeding the maximum permissible pressure.**

- ▶ Damage to the product
- Provide precautionary measures against exceeding the maximum permitted pressures caused by pressure surges (water hammer).

#### **CAUTION**

##### **Use as step.**

- ▶ Damage to the product
- ▶ Risk of slipping-off
- Choose the installation location so that the product cannot be used as a foothold.
- Do not use the product as a step or a foothold.

#### **NOTICE**

##### **Suitability of the product!**

- ▶ The product must be appropriate for the piping system operating conditions (medium, medium concentration, temperature and pressure) and the prevailing ambient conditions.

## NOTICE

### Tools

- ▶ The tools required for installation and assembly are not included in the scope of delivery.
  - Use appropriate, functional and safe tools.
1. Ensure the product is suitable for the relevant application.
  2. Check the technical data of the product and the materials.
  3. Keep appropriate tools ready.
  4. Wear appropriate protective gear, as specified in the plant operator's guidelines.
  5. Observe appropriate regulations for connections.
  6. Have installation work carried out by trained personnel.
  7. Shut off plant or plant component.
  8. Secure plant or plant component against recommissioning.
  9. Depressurize the plant or plant component.
  10. Completely drain the plant (or plant component) and let it cool down until the temperature is below the media vaporization temperature and cannot cause scalding.
  11. Decontaminate, rinse and ventilate the plant or plant component properly.
  12. Lay piping so that the product is protected against transverse and bending forces, and also from vibrations and tension.
  13. Only mount the product between matching aligned pipes (see following chapters).
  14. Flow direction and installation position are optional.

## 11.2 Installation with butt weld spigots

### NOTICE

- ▶ Adhere to good welding practices!

#### 1. Installation variant:

Undo one bolt, remove the other bolts and swivel the centre section aside instead of removing it.

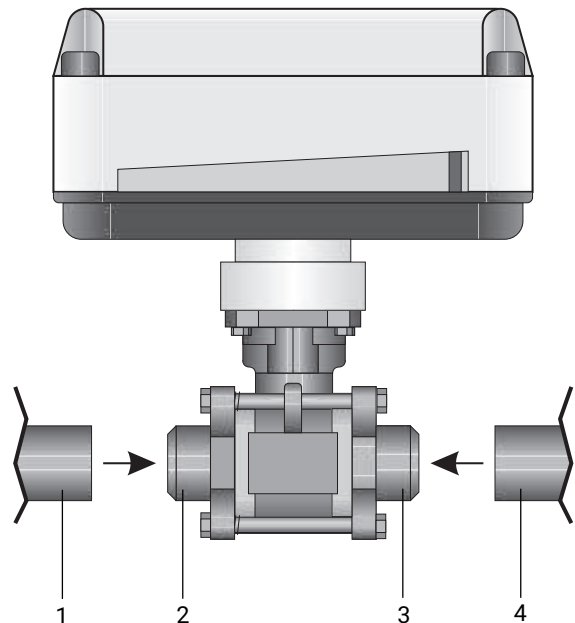

2. Align the pipes **1** and **4** on the left and right with the butt weld spigots **2** and **3**, and attach them to the spigots.

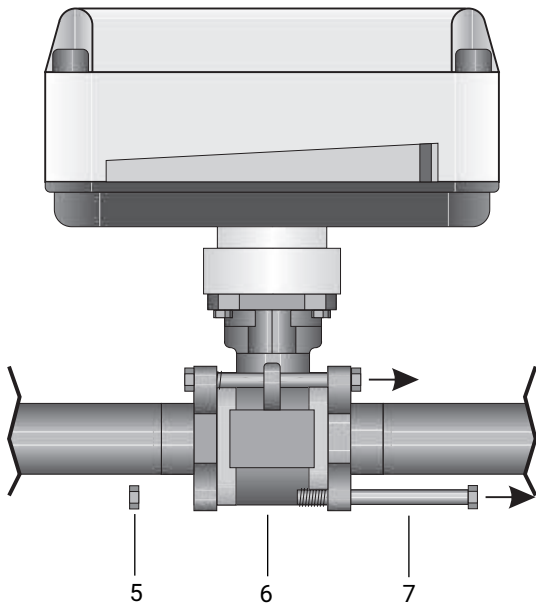

3. Fully unscrew the nuts **5**. With the bolt that goes through the tab, only loosen the nut **5**.
4. Pull out the bolts **7**.
5. Swivel out the ball valve **6** with seat seals and flange seals.
6. Weld the pipes **1** and **4** on the left and right to the butt weld spigots **2** and **3**.
7. Allow the butt weld spigots to cool down.
8. Reinstall the ball valve between the butt weld spigots. Take care that the seat seal and flange seal are correctly positioned. Align the centre section **6** concentrically with butt weld spigots **2** and **3**.
9. Tighten the nuts diagonally, counterhold with a wrench.

Nominal size	Torque [Nm]
DN8	8
DN10	8
DN15	8
DN20	14
DN25	14
DN32	20
DN40	23
DN50	28
DN65	45
DN80	60
DN100	75

**11.3 Installation with threaded connections**

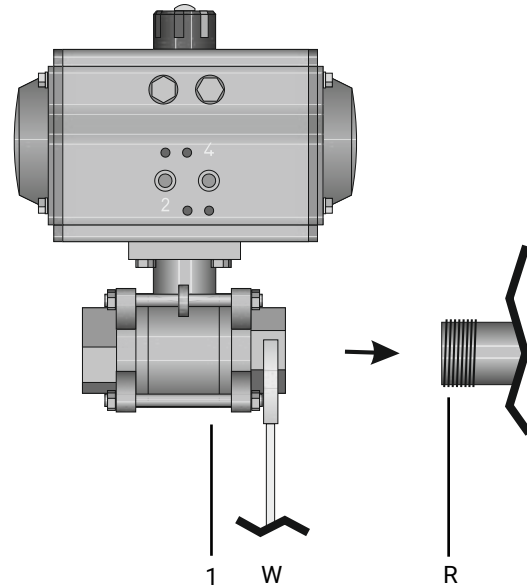

1. Screw ball valve body **1** onto piping **R** using an appropriate thread sealant. The thread sealant is not included in the scope of delivery.
2. Hold in place with open-end wrench **W**.
3. Connect the ball valve body **1** to piping on the other side in a like manner.

### 11.4 Installation with flanged connections

#### NOTICE

► Observe valid standards for mounting flanges!

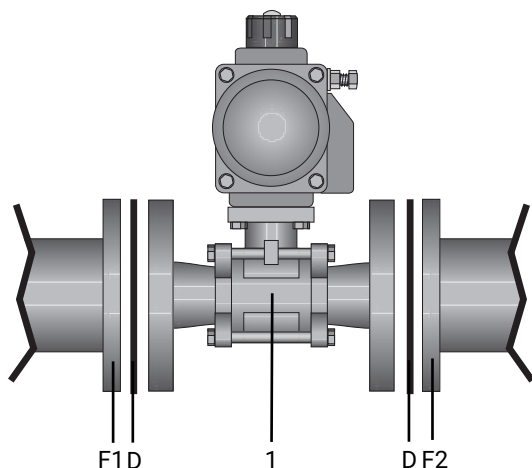

1. Ensure sealing surfaces on the mating flanges are clean and undamaged.
2. Only use connector elements made of approved materials!
3. Install the ball valve in the state it is delivered.
4. Carefully align the ball valve body **1** centrally between the pipes with flanges (**F1** and **F2**).
5. Centre the seals **D** accurately. Seals are not included in the scope of delivery.
6. Connect the ball valve flange and the piping flange using appropriate sealing material and matching bolting. Sealing material and bolts are not included in the scope of delivery.

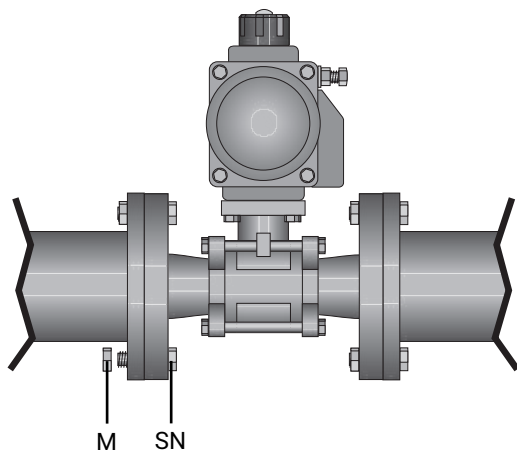

7. Insert bolts **SN** in all holes in the flange.
8. Slightly tighten the bolts **SN** and nuts **M** diagonally.

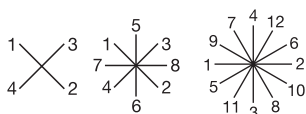

9. Check the alignment of the piping.
10. Tighten the nuts **M** diagonally.

**Observe appropriate regulations for connections!**

### 11.5 After the installation

- Re-attach or reactivate all safety and protective devices.

## 12 Electrical connection

### 12.1 Connection and wiring diagram – actuator version 1006, 1015

#### 12.1.1 ON/OFF actuator (code A0)

12 V DC (code B1) / 24 V DC (code C1)

#### Position of the connectors

Actuator version 1006, 1015

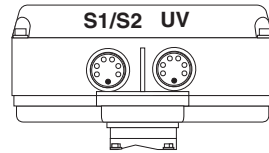

#### Electrical connection



Plug assignment X1, UV

Pin	Description
1	Uv+, direction of travel CLOSED
2	Uv-, direction of travel CLOSED
3	Uv+, direction of travel OPEN
4	Uv-, direction of travel OPEN
5	n.c.
6	n.c.
⊕	PE, protective earth conductor

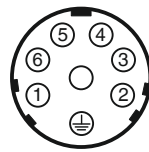

Plug assignment X2, S1/S2

Pin	Description
1	Change-over contact limit switch CLOSED
2	Make contact limit switch CLOSED
3	Break contact limit switch CLOSED
4	Break contact limit switch OPEN
5	Make contact limit switch OPEN
6	Change-over contact limit switch OPEN
⊕	PE, protective earth conductor

#### Connection diagram

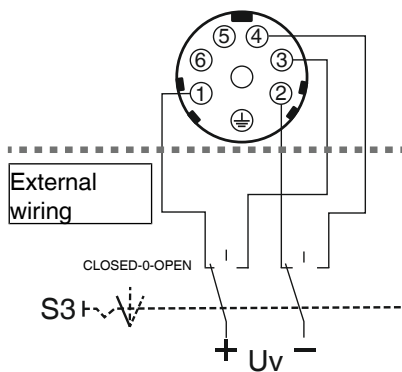

Connection assignment X1, UV

S3	Actuator
CLOS ED	Direction of travel CLOSED
0	OFF
OPEN	Direction of travel OPEN

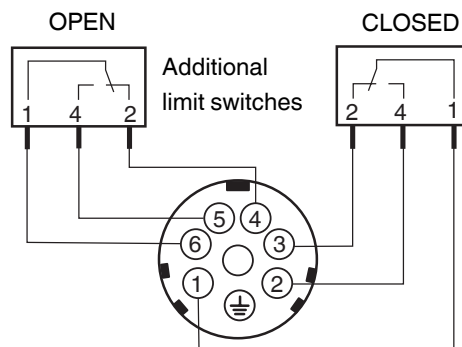

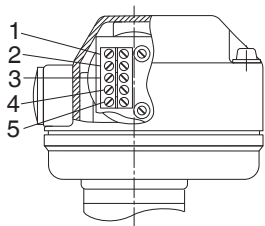

**12 V AC (code B4) / 24 V AC (code C4)****Assignment of the terminal strips**

Item	Description
1	L1, supply voltage
2	N, supply voltage
3	L1, change-over (OPEN/CLOSED)
4	N, change-over (OPEN/CLOSED)
5	PE, protective earth conductor

Preferred direction -OPEN- when all signals are present

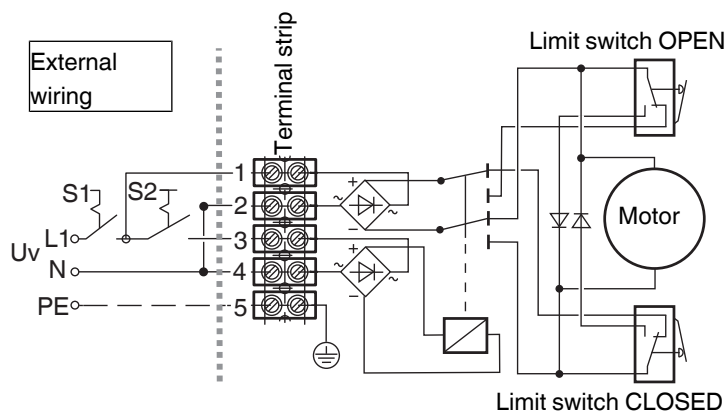
**Connection diagram**

S1	Actuator
0	OFF
1	ON

S2	Direction of travel
0	CLOSED
1	OPEN

**12.1.2 ON/OFF actuator with 2 potential-free limit switches (code AE)**

**12 V DC (code B1) / 24 V DC (code C1)**

**Position of the connectors**

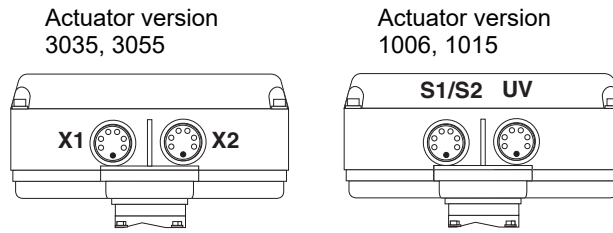

**Electrical connection**



Plug assignment X1, UV

Pin	Description
1	Uv+, direction of travel CLOSED
2	Uv-, direction of travel CLOSED
3	Uv+, direction of travel OPEN
4	Uv-, direction of travel OPEN
5	n.c.
6	n.c.
⊕	PE, protective earth conductor

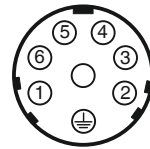

Plug assignment X2, S1/S2

Pin	Description
1	Change-over contact limit switch CLOSED
2	Make contact limit switch CLOSED
3	Break contact limit switch CLOSED
4	Break contact limit switch OPEN
5	Make contact limit switch OPEN
6	Change-over contact limit switch OPEN
⊕	PE, protective earth conductor

**Connection diagram**

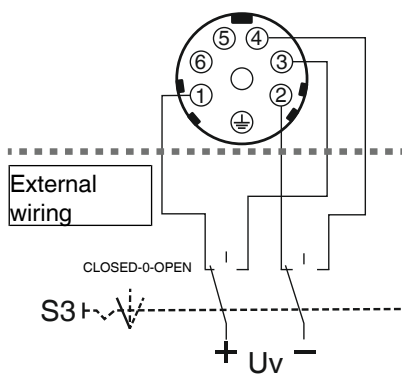

Connection assignment X1, UV

S3	Actuator
CLOSED	Direction of travel CLOSED
0	OFF
OPEN	Direction of travel OPEN

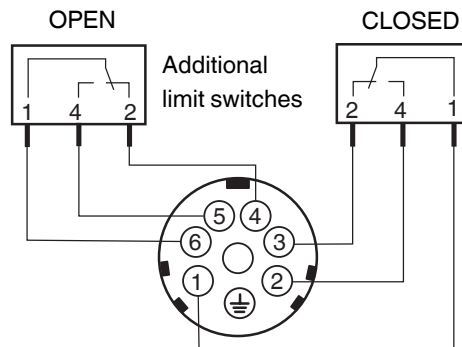

**12 V AC (code B4) / 24 V AC (code C4)**

**Position of the connectors**

Actuator version 1006

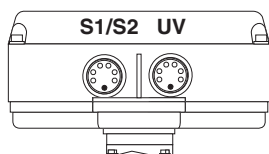

Actuator version 2015

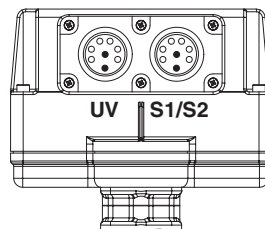

**Electrical connection**



Plug assignment UV

Pin	Description
1	L1, supply voltage
2	N, supply voltage
3	L1, change-over (OPEN/CLOSED)
4	N, change-over (OPEN/CLOSED)
5	n.c.
6	n.c.
⊕	PE, protective earth conductor



Plug assignment S1/S2

Pin	Description
1	Change-over contact limit switch CLOSED
2	Make contact limit switch CLOSED
3	Break contact limit switch CLOSED
4	Break contact limit switch OPEN
5	Make contact limit switch OPEN
6	Change-over contact limit switch OPEN
⊕	PE, protective earth conductor

Preferred direction -OPEN- when all signals are present

**Connection diagram**

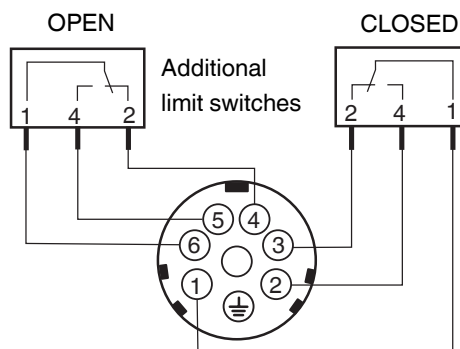
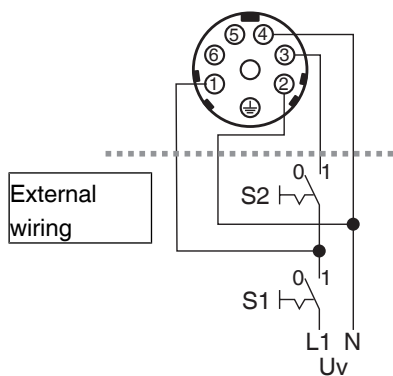

Connection diagram X1, UV

S1	Actuator
0	OFF
1	ON
S2	Direction of travel
0	CLOSED
1	OPEN

**12.2 Connection and wiring diagram – actuator version 2070, 4100, 4200**

**12.2.1 Connection/wiring diagram**

**12.2.1.1 ON/OFF actuator with relay (code 00), 24 V DC (code C1)**

**12.2.1.1.1 Position of the connectors**

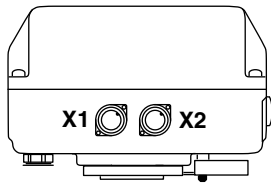

Actuator version 2070

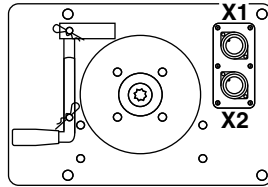

Actuator version 4100, 4200

**12.2.1.1.2 Electrical connection**

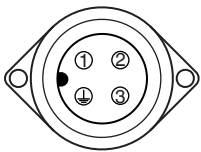

Plug assignment X1

Pin	Description
1	L1 / Uv+, direction of travel CLOSED
2	L1 / Uv+, direction of travel OPEN
3	N / Uv-, neutral conductor
⊕	PE, protective earth conductor

N / L- signals in the unit are separated.

The potential must be assigned by the user.

When the OPEN and CLOSED switches are operated simultaneously the actuator "CLOSES".

**12.2.1.1.3 Connection diagram**

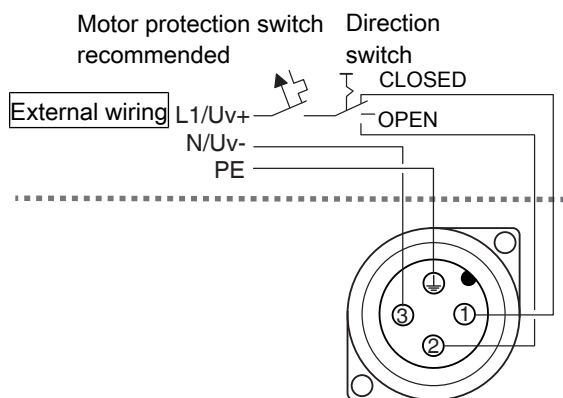

Connection assignment X1

**12.2.1.2 ON/OFF actuator with 2 additional potential-free limit switches, with relay (code 0E), 24 V DC (code C1)**

**12.2.1.2.1 Position of the connectors**

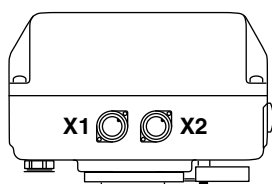

Actuator version 2070

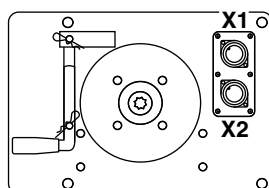

Actuator version 4100, 4200

**12.2.1.2.2 Electrical connection**

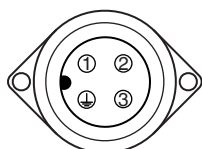

Plug assignment X1

Pin	Description
1	L1 / Uv+, direction of travel CLOSED
2	L1 / Uv+, direction of travel OPEN
3	N / Uv-, neutral conductor
⊕	PE, protective earth conductor

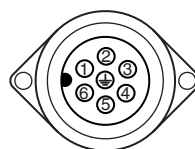

Plug assignment X2

Pin	Description
1	Change-over contact limit switch CLOSED
2	Make contact limit switch CLOSED
3	Break contact limit switch CLOSED
4	Break contact limit switch OPEN
5	Make contact limit switch OPEN
6	Change-over contact limit switch OPEN
⊕	PE, protective earth conductor

N / L- signals in the unit are separated.

The potential must be assigned by the user.

When the OPEN and CLOSED switches are operated simultaneously the actuator "CLOSES".

**12.2.1.2.3 Connection diagram**

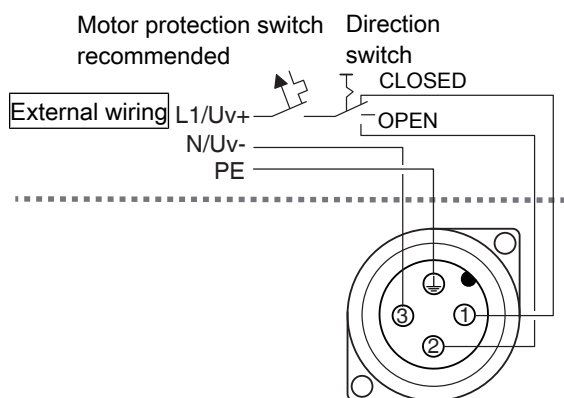

Connection assignment X1

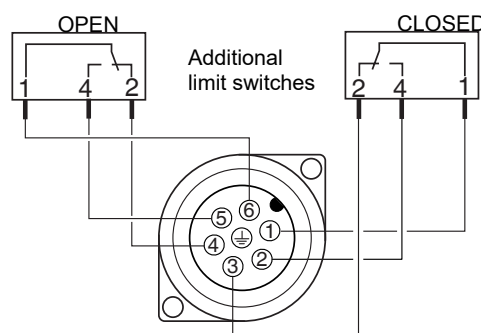

Connection assignment X2

**12.2.1.3 ON/OFF actuator with potentiometer output, with relay (code 0P), 24 V DC (code C1)**

**12.2.1.3.1 Position of the connectors**

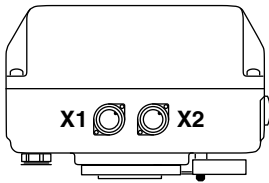

Actuator version 2070

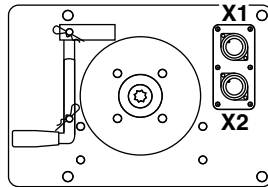

Actuator version 4100, 4200

**12.2.1.3.2 Electrical connection**

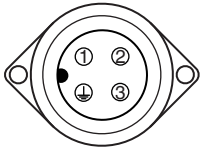

Plug assignment X1

Pin	Description
1	L1 / Uv+, direction of travel CLOSED
2	L1 / Uv+, direction of travel OPEN
3	N / Uv-, neutral conductor
⊕	PE, protective earth conductor

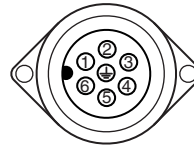

Plug assignment X2

Pin	Description
1	n. c.
2	n. c.
3	n. c.
4	Us-, actual value potentiometer signal voltage minus
5	Us ⊥, actual value potentiometer signal output
6	Us+, actual value potentiometer signal voltage plus
⊕	PE, protective earth conductor

N / L- signals in the unit are separated.  
 The potential must be assigned by the user.  
 When the OPEN and CLOSED switches are operated simultaneously the actuator "CLOSES".

**12.2.1.3.3 Connection diagram**

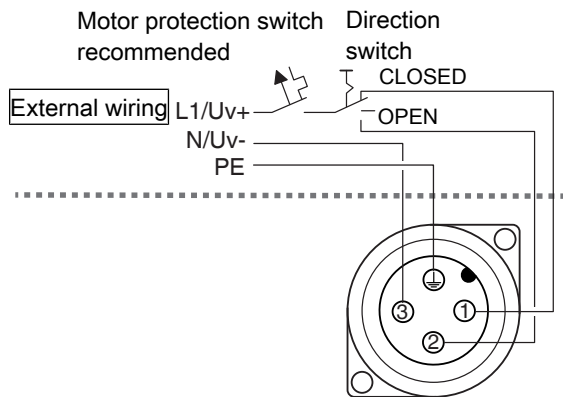

Connection assignment X1

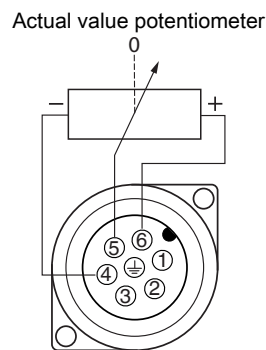

Connection assignment X2

## 13 Limit switches

### DANGER



#### Risk of electric shock!

- ▶ Risk of injury or death (if operating voltage is higher than safe extra low voltage).
- ▶ Adjustments are made with the actuator cover removed.
- ▶ Electric shock can cause severe burns and fatal injury.
- **Always** disconnect the product from power supply!
- Therefore, have all work performed only by qualified electricians.

### CAUTION

#### Incorrectly adjusted limit switch!

- ▶ Actuator continues running.
- ▶ Damage to the actuator.
- Do not move the limit switch too far outwards.

### NOTICE

#### Tools required for setting the limit switches:

- Allen key SW3
- Small Philips head screw driver

### NOTICE

- Always switch the limit switch for signal so that the motor switch is actuated first.
- ⇒ Limit switches for signal and motor are already preset.

### 13.1 Setting the limit switch for 1015, 2015 and 3035

The motorized actuator versions 1015, 2015 and 3035 are supplied in the open position.

The "OPEN" and "CLOSED" end positions are set using limit switches. These are actuated using the levers and can be adjusted by loosening the 2 screws.

**The following drawings differ depending on the actuator version!**

1. Disconnect the plant from power supply and secure against recommissioning.

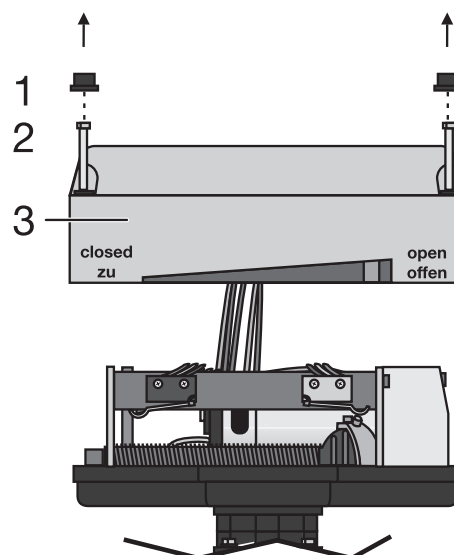

2. Remove the protective caps 1.
3. Undo screws 2.
4. Remove the cover of the actuator 3.

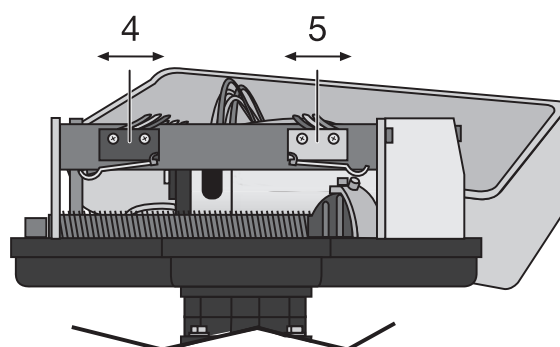

5. Undo the screws on the corresponding limit switch (4 = "CLOSED", 5 = "OPEN").
6. Move limit switches to the desired position.
7. Tighten limit switch screws.

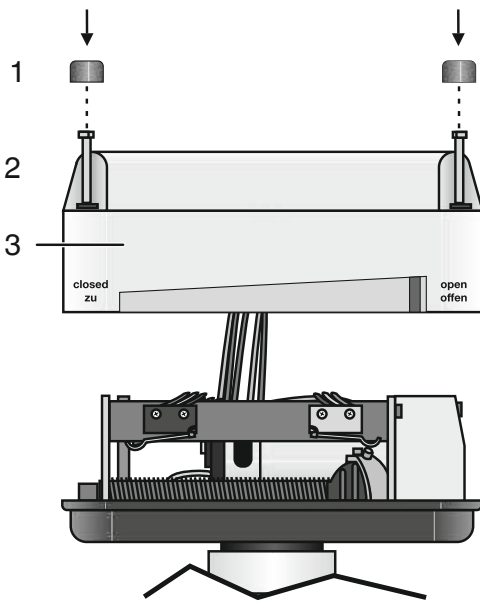

8. Put on cover of actuator 3.
  9. Tighten cover 3.
  10. Put on protective caps 1.
- ⇒ Limit switches are set.

**13.2 Setting the limit switch for 2070, 4100, 4200**

The motorized actuator versions 2070, 4100 and 4200 are supplied in the open position.

The "OPEN" and "CLOSED" end positions are set using limit switches. These are actuated using the levers and can be adjusted by loosening the 2 screws.

**⚠ CAUTION**

**Incorrectly adjusted limit switch!**

- ▶ Actuator continues running.
- ▶ Damage to the actuator.
- Do not move the limit switch too far outwards.

**Versions 00, 0E, 0P:**

- The actuator is not reversible, i.e. it must be stopped briefly when switching over from "OPEN" to "CLOSED" or "CLOSED" to "OPEN".
- For the above actuator types, overall height 1 applies.

**Versions A0, AE, AP, E1, E2:**

- The actuator is reversible, i.e. it can be switched directly from "OPEN" to "CLOSED". To this end, a dead zone of 200 ms is integrated into the electronic system, i.e. when switching over, the actuator does not run for this time.
- Independent of the supply voltage, the OPEN/CLOSE control is freely selectable via a mains supply of 24 V DC, 24 V AC up to 250 V AC or operated directly via a PLC.
- An electronic current limitation limits the torque.
- For the above actuator types (except for code 2070), overall height 2 applies.

**⚠ DANGER**

**Risk of electric shock!**

- ▶ Risk of injury or death (if operating voltage is higher than safe extra low voltage).
- ▶ Adjustments are made with the actuator cover removed.
- ▶ Electric shock can cause severe burns and fatal injury.
- **Always** disconnect the product from power supply!
- Therefore, have all work performed only by qualified electricians.

**14 Commissioning**

**⚠ WARNING**

**Corrosive chemicals!**

- ▶ Risk of caustic burns
- Wear appropriate protective gear.
- Completely drain the plant.

**⚠ CAUTION**

**Leakage!**

- ▶ Emission of dangerous materials
- Provide precautionary measures against exceeding the maximum permitted pressures caused by pressure surges (water hammer).

1. Check the tightness and the function of the product (close and reopen the product).
2. Flush the piping system of new plant and following repair work (the product must be fully open).
  - ⇒ Harmful foreign matter has been removed.
  - ⇒ The product is ready for use.
3. Commission the product.



## 15 Operation

### 15.1 Normal operation

For opening or closing, the product must be activated in accordance with the electrical connection.

### 15.2 Optical position indicator

The actuator has an optical position indicator which indicates the position of the actuator.

#### Actuator versions 1015, 2015, 3035

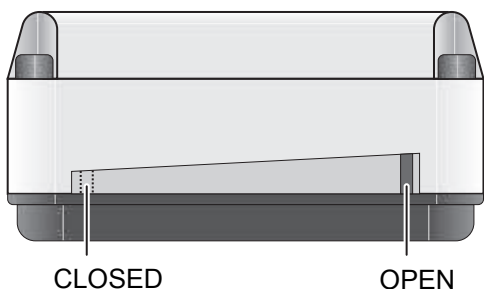

#### Actuator version 2070

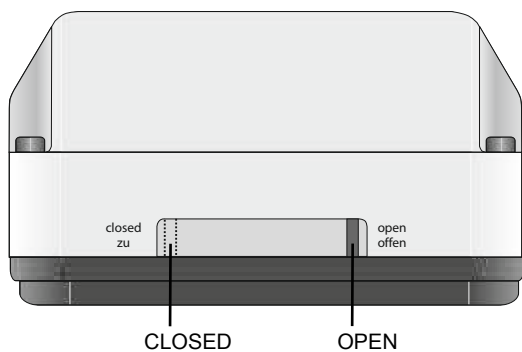

#### Actuator versions 4100, 4200

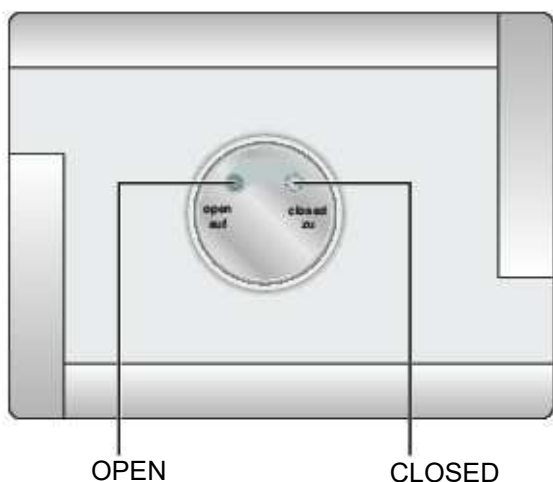

### 15.3 Manual override

#### ⚠ CAUTION

Only actuate the manual override when the power is switched off.

- ▶ Damage to the actuator!

#### ⚠ CAUTION

Set the actuator position to "centred" after using the manual override!

- ▶ Trip cams may be outside the limit switches as the limit switch position was manually exceeded by the manual override.
- ▶ Damage to the actuator.
- Set the actuator position to "centred" before electrical operation.

#### 15.3.1 Manual overrides 1015, 2015, 3035

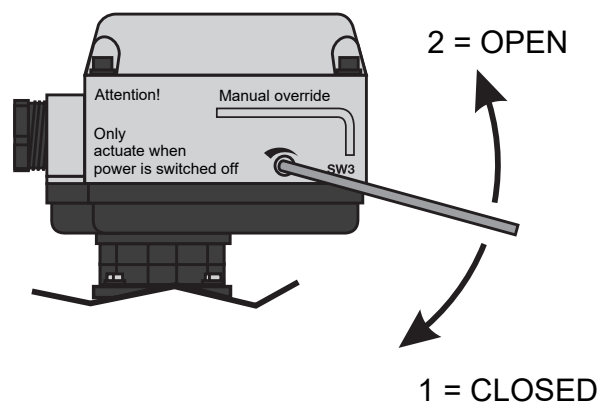

#### Actuator version 1015 and 2015

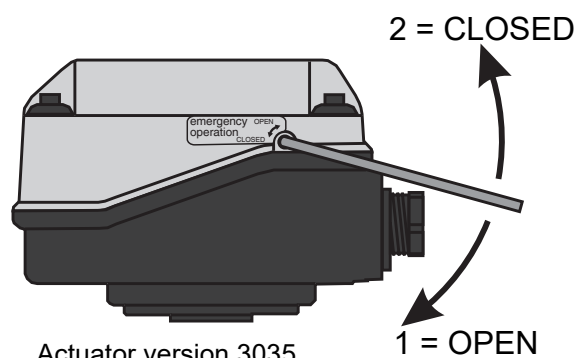

#### Actuator version 3035

1. Disconnect the plant from power supply and secure against recommissioning.
2. Remove red protective cap.
3. To open the valve, turn the Allen key (SW3) clockwise **1** until the position indicator shows "open".
4. To close the valve turn the Allen key (SW3) anti-clockwise **2** until the position indicator shows "closed".
5. Reinsert red protective cap.

**15.3.2 Manual overrides 2070, 4100, 4200**

On the side of the actuator there is a blanking cover for the manual override. The crank handle for manual override is located on the base of the actuator. Actuation of the manual override additionally actuates a switch that shuts off power to the actuator.

**Example: Actuator version 2070**

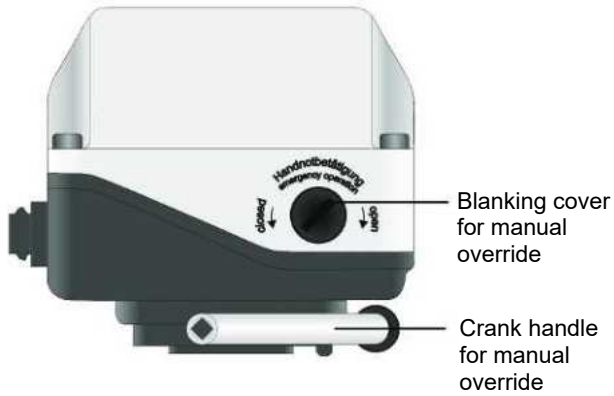

If manual override is required, take the following steps:

1. Unscrew the blanking cover using a screw driver.
2. Insert crank handle and actuate the actuator by hand.

Crank into the desired valve position (in the direction indicated on label):

Actuator version 2070	
Clockwise:	OPEN
Anticlockwise:	CLOSED

Actuator versions 4100, 4200	
Clockwise:	CLOSED
Anticlockwise:	OPEN

## 16 Troubleshooting

Error	Possible cause	Troubleshooting
The product does not open or does not open fully	Actuator defective	Replace the actuator
	Foreign matter in the product	Remove and clean the product
The product does not close or does not close fully	Actuator defective	Replace the actuator (see chapter "Replacing the actuator")
	Foreign matter in the product	Remove and clean the product
The product is leaking between actuator and valve body	Faulty product	Check the product for potential damage, replace the product if necessary
	Seals faulty	Replace seals
Connection between valve body and piping leaking	Incorrect installation	Check installation of valve body in piping
	Flange bolting loose/thread leaking	Retighten flange bolting / reseal threads
	Flange seals faulty	Replace flange seals
Valve body leaking	Valve body faulty	Check valve body for potential damage, replace valve body if necessary

## 17 Inspection/maintenance

### ⚠ WARNING

#### The equipment is subject to pressure!

- ▶ Risk of severe injury or death
- Depressurize the plant or plant component.
- Completely drain the plant or plant component.

### ⚠ CAUTION



#### Hot plant components!

- ▶ Risk of burns
- Only work on plant that has cooled down.

### ⚠ CAUTION

- Servicing and maintenance work must only be performed by trained personnel.
- Do not extend hand lever. GEMÜ shall assume no liability whatsoever for damages caused by improper handling or third-party actions.
- In case of doubt, contact GEMÜ prior to commissioning.

1. Use appropriate protective gear as specified in plant operator's guidelines.
2. Shut off plant or plant component.
3. Secure against recommissioning.
4. Depressurize the plant or plant component.

Ball valves are maintenance-free. No lubrication or routine maintenance of the ball valve shaft is required. The shaft is guided through a PTFE gland packing in the ball valve body. The shaft seal is pretensioned and self-adjusting. However, the operator must carry out regular visual examinations of the ball valves, dependent on the operating conditions and the potential danger in order to prevent leakage and damage.

If there is a leakage at the spindle nut, this can generally be rectified by retightening the spindle nut. However, overtightening the spindle nut must be avoided.

Usually, retightening by between 30° and 60° will be sufficient to rectify the leakage.

## 17.1 General information regarding actuator replacement

### NOTICE

#### The following tools are required for actuator replacement:

- Allen key

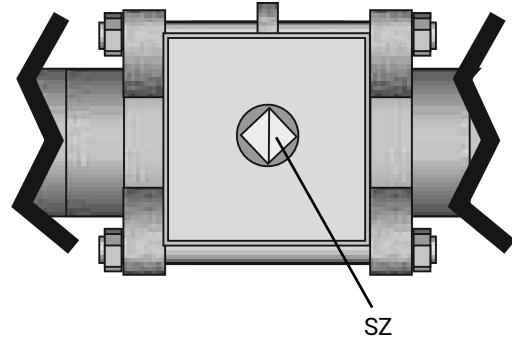

1. Check the position of the ball indicated by the groove **SZ** and compare with position indicator, rotate ball valve to correct position if necessary.
  - ⇒ Groove transverse to piping direction: Ball valve closed.
  - ⇒ Groove in piping direction: Ball valve open.

### NOTICE

- ▶ For flanged bodies, the hand lever is fitted offset by 90°.

### 17.1.1 Replacing the actuator

### ⚠ DANGER



#### Risk of electric shock!

- ▶ Risk of injury or death (if operating voltage is higher than safe extra low voltage).
- ▶ Adjustments are made with the actuator cover removed.
- ▶ Electric shock can cause severe burns and fatal injury.
- **Always** disconnect the product from power supply!
- Therefore, have all work performed only by qualified electricians.

### 17.1.1.1 Removing the actuator

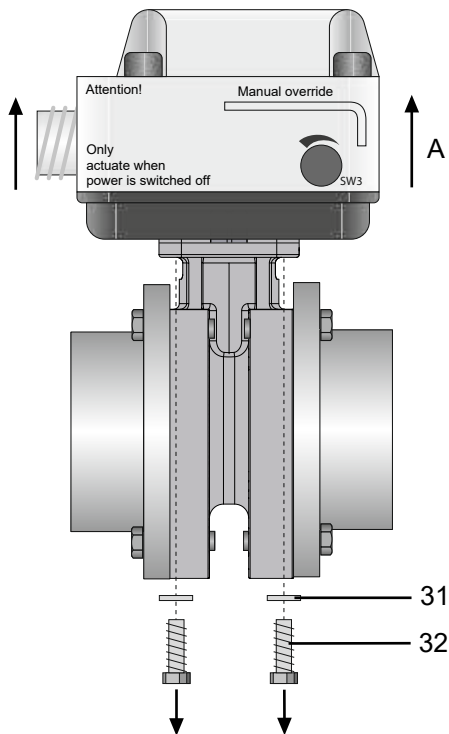

1. Disconnect the actuator from the power supply.
2. Remove the protective caps **30**.
3. Unscrew the hexagon screws **32**.
4. Do not lose the washers **31**.
5. The actuator **A** can be removed from the ball valve body.

### 17.1.1.2 Mounting the actuator

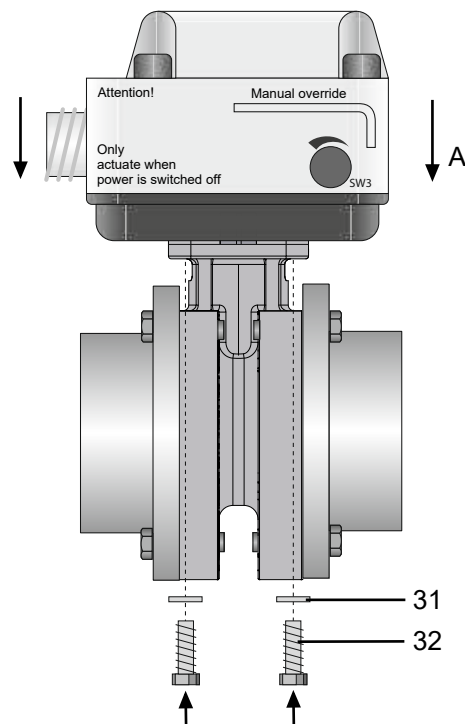

1. Push the new actuator **A** onto the ball valve body.
2. Turn the actuator until the hexagon screws **32** can be inserted.
3. Tighten the hexagon screws **32** with their washers **31** until hand tight.
4. Diagonally tighten the hexagon screws **32** evenly until they are hand tight.
5. Put the protective caps **30** back on.
6. Reconnect the actuator to the power supply.

### 17.1.2 Replacing the seals

#### NOTICE

- Only use genuine GEMÜ spare parts.
- When ordering spare parts, specify the complete order number of the ball valve.

1. Remove the actuator (see chapter "Removing the actuator").

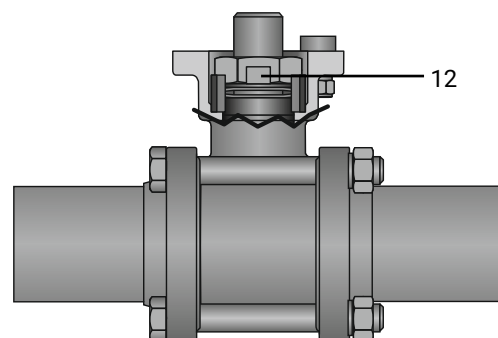

2. Bend the tab **12** of the screw locking device downwards.

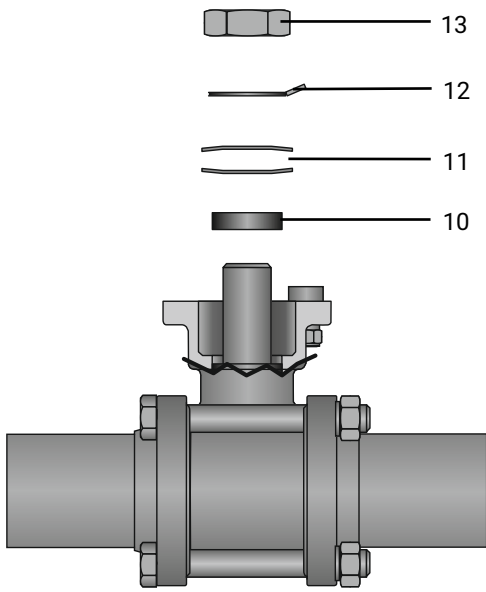

- 3. Loosen the spindle nut **13** and remove.
- 4. Remove the screw locking device **12**.
- 5. Remove the spring washers **11**.
- 6. Remove the stainless steel sleeve **10**.

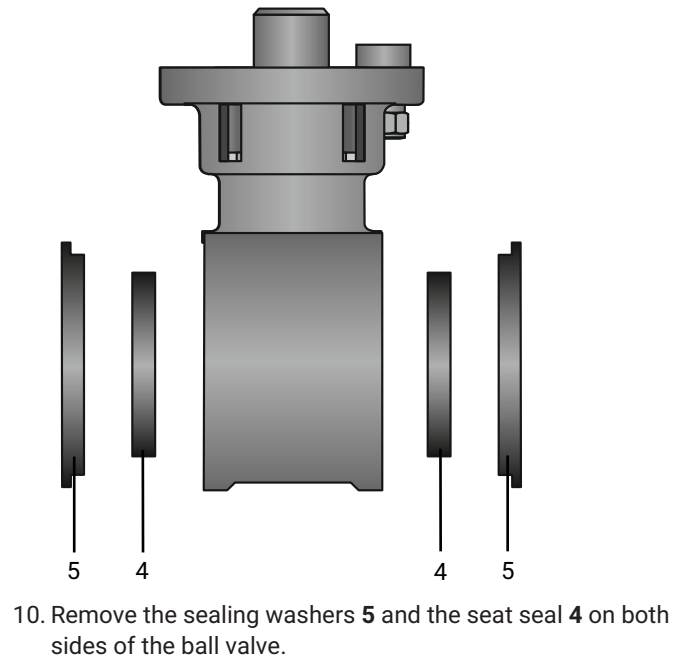

- 10. Remove the sealing washers **5** and the seat seal **4** on both sides of the ball valve.

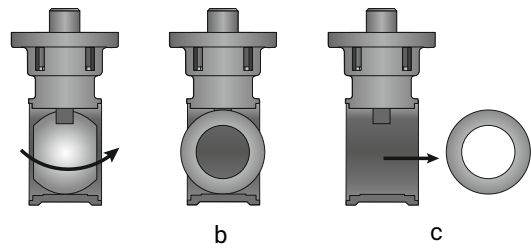

- 11. Move the ball to the closed position **b**.
- 12. Remove the ball **c**.

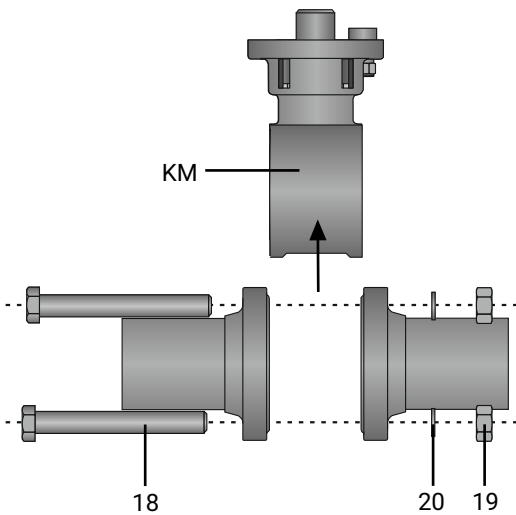

- 7. Loosen the nuts **19** of the flange bolts **18** of the ball valve and remove with washers **20**.
- 8. Remove the flange bolts **18**.
- 9. Remove the centre section **KM**.

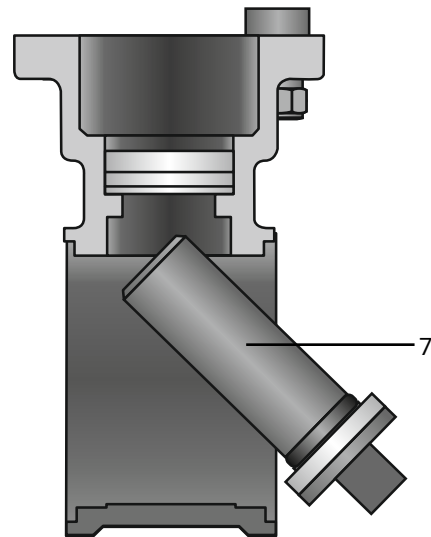

- 13. Carefully press the spindle **7** into the body and remove.

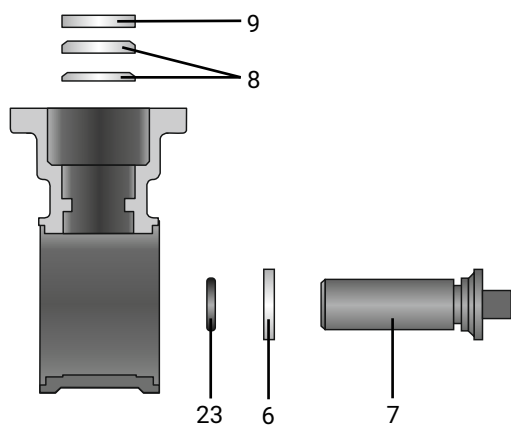

14. Remove the seals **9** and **8** upwards from the ball valve.

#### NOTICE

- ▶ Seal **8**:  
DN 8–50: 2 pieces  
DN 65–100: 3 pieces

15. Remove O-ring **23** from spindle **7**.

#### NOTICE

- ▶ O-ring **23** is not available for connection type spigot ASME BPE code 59.

16. Remove seal **6** from spindle **7**.

17. Mount the seals and the ball valve in reverse order.

**17.2 Spare parts**

Spare parts for connection types 1, 8, 11, 17, 19, 31, 60

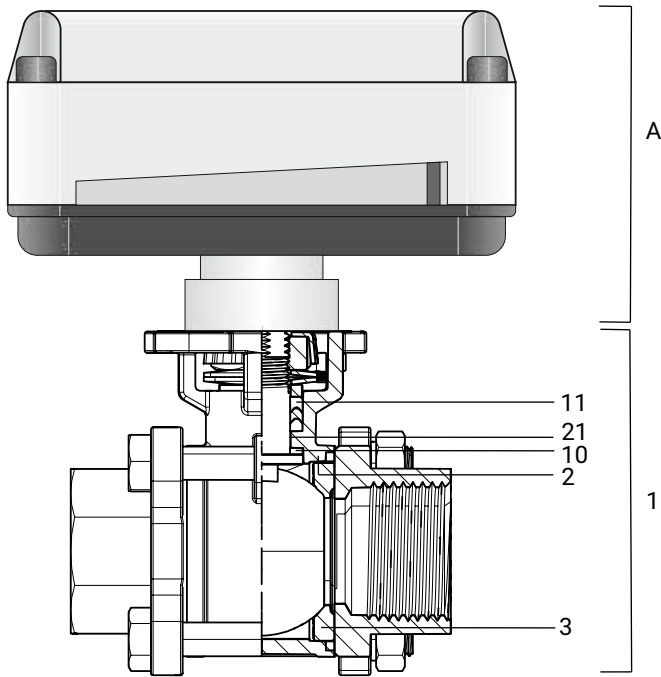

Item	Name	Order designation
1	Ball valve body assembly	BB02...
2	Body seal	BB02 DN...SDS D60 5
3	Seat and flange seal	
10	Conical spindle seal	
11	V-ring spindle packing	
21	O-ring	
A	Actuator	See actuator designation. Dependent on the actuator version.



## Spare parts for connection type 59

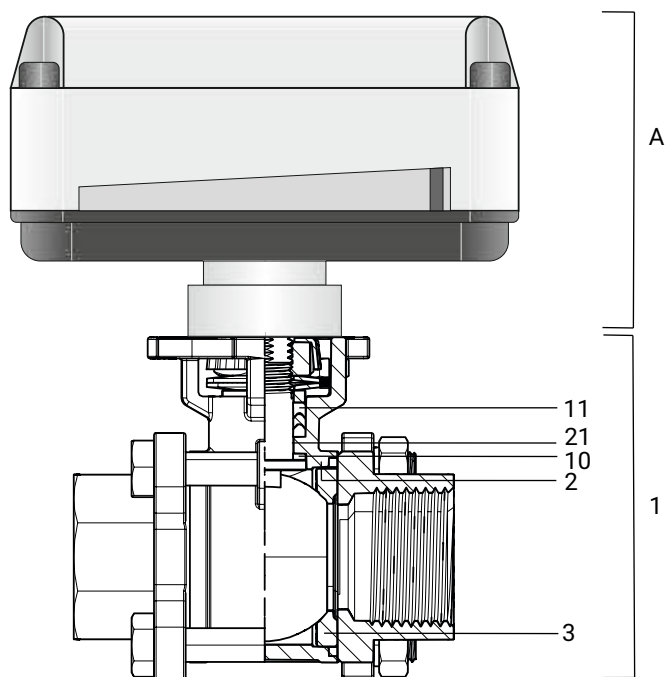

Item	Name	Order designation
1	Ball valve body assembly	BB02
2	Body seal	BB02 DN...SDS D59 5
3	Seat and flange seal	
10	Conical spindle seal	
11	V-ring spindle packing	
21	O-ring	
A	Actuator	See actuator designation. Dependent on the actuator version.

### **18 Removal from piping**

1. Remove the clamp or screw connections in reverse order to installation.
2. Remove welded or solvent cemented connections using a suitable cutting tool.
3. Observe the safety information and accident prevention regulations.

### **19 Disposal**

1. Pay attention to adhered residual material and gas diffusion from penetrated media.
2. Dispose of all parts in accordance with the disposal regulations/environmental protection laws.

### **20 Returns**

Legal regulations for the protection of the environment and personnel require that the completed and signed return delivery note is included with the dispatch documents. Returned goods can be processed only when this note is completed. If no return delivery note is included with the product, GEMÜ cannot process credits or repair work but will dispose of the goods at the operator's expense.

1. Clean the product.
2. Request a return delivery note from GEMÜ.
3. Complete the return delivery note.
4. Send the product with a completed return delivery note to GEMÜ.

**21 EU Declaration of Incorporation according to the EC Machinery Directive 2006/42/EC, Annex II B**



## EU Declaration of Incorporation

**according to the EC Machinery Directive 2006/42/EC, Annex II B**

We, the company GEMÜ Gebr. Müller Apparatebau GmbH & Co. KG  
Fritz-Müller-Strasse 6-8  
74653 Ingelfingen-Criesbach, Germany

hereby declare under our sole responsibility that the below-mentioned product complies with the relevant essential health and safety requirements in accordance with Annex I of the above-mentioned Directive.

**Product:** GEMÜ B52  
**Product name:** Motorized ball valve  
**The following essential health and safety requirements of the EC Machinery Directive 2006/42/EC, Annex I have been applied or adhered to:** 1.1.2.; 1.1.3.; 1.1.5.; 1.3.2.; 1.3.4.; 1.3.7.; 1.3.8.; 1.5.1.; 1.5.13.; 1.5.2.; 1.5.4.; 1.5.6.; 1.5.7.; 1.5.8.; 1.6.1.; 1.6.3.; 1.6.5.; 1.7.1.; 1.7.1.1.; 1.7.2.; 1.7.3.; 1.7.4.; 1.7.4.1.; 1.7.4.2.; 1.7.4.3.  
**The following harmonized standards (or parts thereof) have been applied:** EN ISO 12100:2010

We also declare that the specific technical documents have been created in accordance with part B of Annex VII.

The manufacturer undertakes to transmit relevant technical documents on the partly completed machinery to the national authorities in response to a reasoned request. This communication takes place electronically.

This does not affect the industrial property rights.

**The partly completed machinery may be commissioned only if it has been determined, if necessary, that the machinery into which the partly completed machinery is to be installed meets the provisions of the Machinery Directive 2006/42/EC.**

M. Barghoorn  
Head of Global Technics

Ingelfingen, 09/02/2023

**22 Declaration of conformity according to 2014/68/EU (Pressure Equipment Directive)**

# EU Declaration of Conformity

## in accordance with 2014/68/EU (Pressure Equipment Directive)

We, the company  
GEMÜ Gebr. Müller Apparatebau GmbH & Co. KG  
Fritz-Müller-Strasse 6-8  
74653 Ingelfingen-Criesbach, Germany

declare that the product listed below complies with the safety requirements of the Pressure Equipment Directive 2014/68/EU.

**Description of the pressure equipment:** GEMÜ B52  
**Notified body:** TÜV Rheinland Industrie Service GmbH  
**Number:** 0035  
**Certificate no.:** 01 202 926/Q-02 0036  
**Conformity assessment procedure:** Module H  
**Technical standard applied in parts:** EN 1983, AD 2000

**Note for products with a nominal size  $\leq$  DN 25:**

The products are developed and produced according to GEMÜ process instructions and quality standards which comply with the requirements of ISO 9001 and ISO 14001.

According to Article 4, Paragraph 3 of the Pressure Equipment Directive 2014/68/EU these products must not be identified by a CE-label.

**Other applied standards/ remarks:**

- DIN EN ISO 5211
- DIN EN 558
- AD 2000

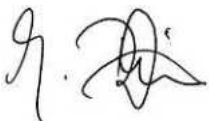

Joachim Brien  
Head of Technical Department

**23 EU Declaration of Conformity in accordance with 2014/30/EU (EMC Directive)**



**EU Declaration of Conformity**  
**in accordance with 2014/30/EU (EMC Directive)**

We, the company GEMÜ Gebr. Müller Apparatebau GmbH & Co. KG  
Fritz-Müller-Strasse 6-8  
74653 Ingelfingen-Criesbach, Germany

hereby declare under our sole responsibility that the below-mentioned product complies with the regulations of the above-mentioned Directive.

**Product:** GEMÜ B52  
**Product name:** Motorized ball valve  
**The following harmonized standards (or parts thereof) have been applied:** EN 61000-6-4:2007/A1:2011

A handwritten signature in blue ink, appearing to read "M. Barghoorn", written over a horizontal line.

M. Barghoorn  
Head of Global Technics  
Ingelfingen, 09/02/2023

**24 EU Declaration of Conformity in accordance with 2014/35/EU (Low Voltage Directive)**



---

**EU Declaration of Conformity**  
***in accordance with 2014/35/EU (Low Voltage Directive)***

We, the company GEMÜ Gebr. Müller Apparatebau GmbH & Co. KG  
Fritz-Müller-Strasse 6-8  
74653 Ingelfingen-Criesbach, Germany

hereby declare under our sole responsibility that the below-mentioned product complies with the regulations of the above-mentioned Directive.

**Product:** GEMÜ B52  
**Product name:** Motorized ball valve  
**Product version:** Valid for product versions with GEMÜ type 9428 and 9468 actuators  
**The following harmonized standards (or parts thereof) have been applied:** EN IEC 61010-2-201:2018; EN 61010-1:2010/A1:2019/AC:2019-04

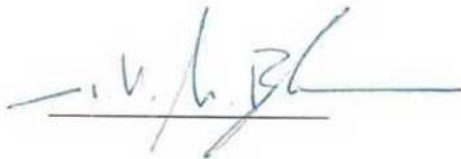

M. Barghoorn  
Head of Global Technics  
Ingelfingen, 09/02/2023



GEMÜ Gebr. Müller Apparatebau GmbH & Co. KG  
Fritz-Müller-Straße 6-8, 74653 Ingelfingen-Criesbach, Germany  
Phone +49 (0) 7940 1230 · info@gemue.de  
www.gemu-group.com

Subject to alteration

05.2024 | 88735965