

GEMÜ R639 eSyStep

Motorized diaphragm valve



Features

- CIP/SIP capable (only with stainless steel distance piece)
- Open/close function or with integrated positioner
- Actuating speed max. 3 mm/s
- Parameterizable via IO-Link
- On-site or remote end position programming via programming input
- Various functions integrated (e.g. feedback, stroke limiter, etc.)

Description

The GEMÜ R639 eSyStep 2/2-way diaphragm valve is electrically operated. The eSyStep electric actuator is available as On/Off actuator or with integrated positioner. An integral optical and electrical position indicator is standard. The self-locking actuator holds its position in a stable manner when idle and in the event of power supply failure.

Technical specifications

- **Media temperature:** -10 to 80 °C
- **Ambient temperature:** 0 to 50 °C
- **Operating pressure :** 0 to 8 bar
- **Nominal sizes:** DN 12 to 50
- **Body configurations:** 2/2-way body
- **Connection types:** Flange | Flare | Solvent cement socket | Spigot | Threaded connection | Union end
- **Connection standards:** BS | DIN | ISO | JIS
- **Body materials:** ABS | Inliner PP-H, grey / outliner PP, reinforced | Inliner PVDF / outliner PP, reinforced | Inliner PVDF/outliner PP, reinforced | PP, reinforced | PP-H, natural | PVC-U, grey | PVDF
- **Diaphragm materials:** EPDM | FKM | NBR | PTFE/EPDM
- **Supply voltage:** 24 V DC
- **Actuating speed:** max. 3 mm/s
- **Protection class:** IP 65
- **Conformities:** EAC | FDA

Technical data depends on the respective configuration



Product description

Construction

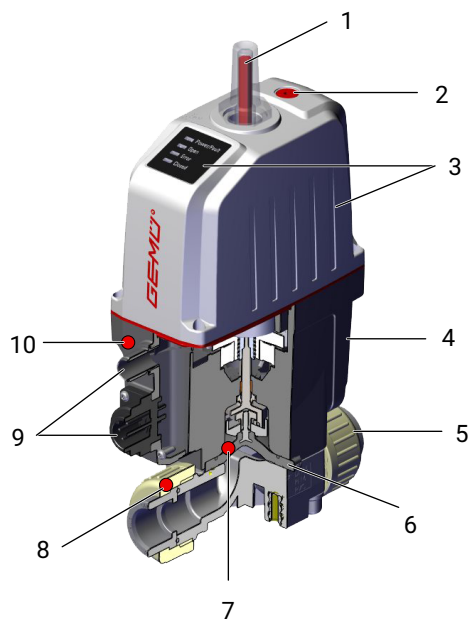

Item	Name	Materials
1	Optical position indicator	PA 12
2	Manual override	
3	Actuator top with LED display	Reinforced polyamide
4	Actuator base	Reinforced polyamide
5	Valve body	PVC-U, grey ABS PP, reinforced PVDF inliner PP-H, grey, outliner PP, reinforced inliner PVDF/outliner PP, reinforced PP-H, natural
6	Diaphragm	EPDM, FKM, NBR, PTFE / EPDM
7	CONEXO diaphragm RFID chip (see Conexo information)	
8	CONEXO body RFID chip (see Conexo information)	
9	Electrical connections	
10	CONEXO actuator RFID chip (see Conexo information)	

GEMÜ CONEXO

The interaction of valve components that are equipped with RFID chips and an associated IT infrastructure actively increase process reliability.



Thanks to serialization, every valve and every relevant valve component such as the body, actuator or diaphragm, and even automation components, can be clearly traced and read using the CONEXO pen RFID reader. The CONEXO app, which can be installed on mobile devices, not only facilitates and improves the "installation qualification" process, but also makes the maintenance process much more transparent and easier to document. The app actively guides the maintenance technician through the maintenance schedule and directly provides him with all the information assigned to the valve, such as test reports, testing documentation and maintenance histories. The CONEXO portal acts as a central element, helping to collect, manage and process all data.

For further information on GEMÜ CONEXO please visit:

www.gemu-group.com/conexo

Ordering

GEMÜ Conexo must be ordered separately with the ordering option "CONEXO".

Overview of available functions

Function	Control module – OPEN/CLOSE control (Code AE, A5, A6)	Control module – positioner (Code S0, S5, S6)
OPEN/CLOSE control	X	X
Positioner		X
Manual override	X	X
Optical status and position indicator	X	X
On-site initialization	X	X
Deactivation of on-site initialization	X	X
Initialization via digital input	X	X
Initialization via IO-Link	X	X
Feedback for operating mode	X	X
Actuation OPEN	X	X
Actuation CLOSED	X	X
Actuation, analogue		X
Position feedback OPEN	X	X
Position feedback CLOSED	X	X
Position feedback analogue		X
Location function	X	X
Error output	X	X
Actuating speed adjustable	X	
Actuating force adjustable	X	X
Inversion of LED colours	X	X
Cycle counter	X	
Error counter	X	
Operating time determination	X	X
Switch point setting (tolerance)	X	X
Inversion input/output logic	X	X
Adjustable error action	X	X
Safe/On	X	X
Direction reversal		X
Open tight		X
Close tight		X
Split range		X
Stroke limiter/seal adjuster		X

Availability

Availability of valve bodies

Spigot

MG	DN	Connection type code ¹⁾							
		0			20		28	30	7X
		Material code ²⁾							
		1	5, 20	71, 75	20	71, 75	20	1, 4	1, 4, 71, 75
10	15	-	-	-	-	-	X	-	X
20	15	X	-	X	-	X	-	X	X
	20	X	-	X	-	X	-	X	X
	25	X	-	X	-	X	-	X	X
25	32	X	-	X	-	X	-	X	X
40	40	X	-	X	-	X	-	X	X
	50	X	-	X	-	X	-	X	X

MG = diaphragm size, X = standard

1) Connection type

Code 0: Spigot DIN

Code 20: Spigot for IR butt welding

Code 28: Spigot for IR butt welding, BCF

Code 30: Spigot – inch, for welding or solvent cementing, depending on the body material

Code 7X: Body with threaded spigots for unions

2) Valve body material

Code 1: PVC-U, grey

Code 4: ABS

Code 5: PP, reinforced

Code 20: PVDF

Code 71: Inliner PP-H, grey, outliner PP, reinforced

Code 75: Inliner PVDF/outliner PP, reinforced

Union end

MG	DN	Connection type code ¹⁾																							
		07						7						7R, 3P	33	3M	3T	78							
		Material code ²⁾																							
		1	4	5	20	71	75	1	4	5	20	N5	71	75	1	1	4	1	1	5	20	N5	71	75	
10	12	X	X	-	-	X	X	-	-	-	-	-	-	-	-	-	-	-	-	-	-	-	-	-	
	15	X	X	-	-	X	X	X	-	X	X	X	-	-	-	X	-	-	-	X	X	X	-	-	
20	15	X	X	-	-	X	X	X	X	-	-	-	X	X	X	X	X	X	X	X	-	-	-	X	X
	20	X	X	-	-	X	X	X	X	-	-	-	X	X	X	X	X	X	X	X	-	-	-	X	X
	25	X	X	-	-	X	X	X	X	-	-	-	X	X	X	X	X	X	X	X	-	-	-	X	X
25	32	X	X	-	-	X	X	X	X	-	-	-	X	X	X	X	X	X	X	X	-	-	-	X	X
40	40	X	X	-	-	X	X	X	X	-	-	-	X	X	X	X	X	X	X	X	-	-	-	X	X
	50	X	X	-	-	X	X	X	X	-	-	-	X	X	X	X	X	X	X	X	-	-	-	X	X

MG = diaphragm size, X = standard

1) Connection type

Code 07: Spigot body with GEMÜ 1035 union end, DIN insert (socket)

Code 7: Union end with insert (socket) – DIN

Code 7R: Union end with insert (Rp threaded socket) – DIN

Code 33: Union end with inch insert – BS (socket)

Code 3M: Union end with inch insert – ASTM (socket)

Code 3P: Union end with NPT threaded socket insert

Code 3T: Union end with insert – JIS (socket)

Code 78: Union end with insert (for IR butt welding) – DIN

2) Valve body material

Code 1: PVC-U, grey

Code 4: ABS

Code 5: PP, reinforced

Code 20: PVDF

Code 71: Inliner PP-H, grey, outliner PP, reinforced

Code 75: Inliner PVDF/outliner PP, reinforced

Code N5: PP-H, natural

Threaded socket

MG	DN	Connection type code 1 ¹⁾
		Material code 1, 5, 20 ²⁾
10	12	X

MG = diaphragm size, X = standard

1) Connection type

Code 1: Threaded socket DIN ISO 228

2) Valve body material

Code 1: PVC-U, grey

Code 5: PP, reinforced

Code 20: PVDF

Solvent cement socket

MG	DN	Connection type code 2 ¹⁾
		Material code 1 ²⁾
10	12	X

MG = diaphragm size, X = standard

1) Connection type

Code 2: Solvent cement socket DIN

2) Valve body material

Code 1: PVC-U, grey

Flange

MG	DN	Connection type code ¹⁾					
		4			39		
		Material code ²⁾					
		1	71	75	1	71	75
20	15	X	X	X	X	X	X
	20	X	X	X	X	X	X
	25	X	X	X	X	X	X
25	32	X	X	X	X	X	X
40	40	X	X	X	X	X	X
	50	X	X	X	X	X	X

MG = diaphragm size, X = standard

1) **Connection type**

Code 4: Flange EN 1092, PN 10, form B, face-to-face dimension FTF EN 558 series 1, ISO 5752, basic series 1

Code 39: Flange ANSI Class 125/150 RF, face-to-face dimension FTF EN 558 series 1, ISO 5752, basic series 1, length only for body configuration D

2) **Valve body material**

Code 1: PVC-U, grey

Code 71: Inliner PP-H, grey, outliner PP, reinforced

Code 75: Inliner PVDF/outliner PP, reinforced

Flare

MG	DN	Connection type code 75 ¹⁾
		Material code N5 ²⁾
10	15	X
	20	X

MG = diaphragm size, X = standard

1) **Connection type**

Code 75: Flare connection with PVDF union nut

2) **Valve body material**

Code N5: PP-H, natural

Availability of mounting plate

MG	DN	Material code ¹⁾
10	DN 12	X
	DN 15	X
	DN 20	X

MG = diaphragm size, X = standard

1) **Valve body material**

Code 20: PVDF

Code N5: PP-H, natural

Availability of product compliance

	Diaphragm material code ¹⁾	Body material code ²⁾
Food		
FDA	54, 5M	20, 71, 75

1) **Diaphragm material**

Code 54: PTFE/EPDM one-piece

Code 5M: PTFE/EPDM two-piece

2) **Valve body material**

Code 20: PVDF

Code 71: Inliner PP-H, grey, outliner PP, reinforced

Code 75: Inliner PVDF/outliner PP, reinforced

Order data

The order data provide an overview of standard configurations.

Please check the availability before ordering. Other configurations available on request.

Order codes

1 Type	Code
Diaphragm valve, electrically operated, eSyStep	R639

2 DN	Code
DN 12	12
DN 15	15
DN 20	20
DN 25	25
DN 32	32
DN 40	40
DN 50	50

3 Body configuration	Code
2/2-way body	D

4 Connection type	Code
Spigot	
Spigot DIN	0
Spigot for IR butt welding	20
Spigot for IR butt welding, BCF	28
Spigot – inch, for welding or solvent cementing, depending on the body material	30
Body with threaded spigots for unions	7X
Union end	
Union end with insert (socket) – DIN	7
Spigot body with GEMÜ 1035 union end, DIN insert (socket)	07
Union end with insert (Rp threaded socket) – DIN	7R
Union end with inch insert – BS (socket)	33
Union end with inch insert – ASTM (socket)	3M
Union end with NPT threaded socket insert	3P
Union end with insert – JIS (socket)	3T
Union end with insert (for IR butt welding) – DIN	78
For DN 65 code 07: Spigot body with fitting screw connection see data sheet 1035.	
Threaded socket	
Threaded socket DIN ISO 228	1
Solvent cement socket	
Solvent cement socket DIN	2
Flange	
Flange EN 1092, PN 10, form B, face-to-face dimension FTF EN 558 series 1, ISO 5752, basic series 1	4
Flange ANSI Class 125/150 RF, face-to-face dimension FTF EN 558 series 1, ISO 5752, basic series 1, length only for body configuration D	39

4 Connection type	Code
Flare	
Flare connection with PVDF union nut	75

5 Valve body material	Code
PVC-U, grey	1
ABS	4
PP, reinforced	5
PVDF	20
Inliner PP-H, grey, outliner PP, reinforced	71
Inliner PVDF/outliner PP, reinforced	75
PP-H, natural	N5

6 Diaphragm material	Code
Elastomer	
NBR	2
FKM	4
EPDM	29
PTFE	
PTFE/EPDM one-piece	54
PTFE/EPDM two-piece	5M
Note: The PTFE/EPDM diaphragm (code 5M) is available from diaphragm size 25.	

7 Voltage/Frequency	Code
24 V DC	C1

8 Control module	Code
ON/OFF actuator, additional end position indicators	AE
ON/OFF actuator, additional end position indicators, configured for emergency power supply module (NC)	A5
ON/OFF actuator, additional end position indicators, configured for emergency power supply module (NO)	A6
Positioner	S0
Positioner, configured for emergency power supply module (NC)	S5
Positioner, configured for emergency power supply module (NO)	S6

9 Actuator version	Code
Actuator size 0 diaphragm size 10	0C
Actuator size 1	1A

10 Mounting plate	Code
Including mounting plate	M
Without	

Order example

Ordering option	Code	Description
1 Type	R639	Diaphragm valve, electrically operated, eSyStep
2 DN	15	DN 15
3 Body configuration	D	2/2-way body
4 Connection type	7	Union end with insert (socket) – DIN
5 Valve body material	1	PVC-U, grey
6 Diaphragm material	29	EPDM
7 Voltage/Frequency	C1	24 V DC
8 Control module	S0	Positioner
9 Actuator version	0C	Actuator size 0 diaphragm size 10
10 Mounting plate		Without

Technical data

Medium

Working medium: Corrosive, inert, gaseous and liquid media which have no negative impact on the physical and chemical properties of the body and diaphragm material.

Temperature

Media temperature:

Valve body material	Media temperature
PVC-U, grey (code 1)	10 – 60 °C
ABS (code 4)	-10 – 60 °C
PP, reinforced (code 5)	5 – 80 °C
PVDF (code 20)	-10 – 80 °C
Inliner PP-H grey / outliner PP, reinforced (code 71)	5 – 80 °C
Inliner PVDF / outliner PP, reinforced (code 75)	-10 – 80 °C
PP-H, natural (code N5)	5 – 80 °C

Ambient temperature:

Valve body material	Ambient temperature
PVC-U, grey (code 1)	10 – 50 °C
ABS (code 4)	-10 – 50 °C
PP, reinforced (code 5)	5 – 50 °C
PVDF (code 20)	-10 – 50 °C
Inliner PP-H grey / outliner PP, reinforced (code 71)	5 – 50 °C
Inliner PVDF / outliner PP, reinforced (code 75)	-5 – 50 °C
PP-H, natural (code N5)	5 – 50 °C

Pressure

Operating pressure:

MG	DN	Actuator version	Diaphragm materials	
			Elastomer	PTFE
10	12 - 20	0C	0 - 6	0 - 6
20	15 - 25	1A	0 - 8	0 - 8
25	32	1A	0 - 8	0 - 8
40	40 - 50	1A	0 - 8	0 - 4

MG = diaphragm size

All pressures are gauge pressures. Operating pressure values were determined with static operating pressure applied on one side of a closed valve. Sealing at the valve seat and atmospheric sealing is ensured for the given values.

Information on operating pressures applied on both sides and for high purity media on request.

The operating pressures apply at room temperature. In case of deviating temperatures, observe the pressure / temperature correlation.

Pressure rating: PN 10

Leakage rate: Leakage rate A to P11/P12 EN 12266-1

Pressure/temperature correlation:

MG	Actuator version	Materials	Code	Temperatures in °C (valve body)										
				-10	0	5	10	20	30	40	50	60	70	80
10	0C	PVC-U	1	-	-	-	6.0	6.0	6.0	6.0	3.5	1.5	-	-
		PP-H	5	-	-	6.0	6.0	6.0	6.0	6.0	5.5	4.0	2.7	1.5
		PVDF	20	6.0	6.0	6.0	6.0	6.0	6.0	6.0	6.0	6.0	5.4	4.7
		PP-H-Natur	N5	-	-	6.0	6.0	6.0	6.0	6.0	5.5	4.0	2.7	1.5
20, 25	1A	PVC-U	1	-	-	-	8.0	8.0	8.0	6.0	3.5	1.5	-	-
		ABS	4	8.0	8.0	8.0	8.0	8.0	8.0	6.0	4.0	2.0	-	-
		PP-H	71	-	-	8.0	8.0	8.0	8.0	7.0	5.5	4.0	2.7	1.5
		PVDF	75	8.0	8.0	8.0	8.0	8.0	8.0	8.0	7.1	6.3	5.4	4.7

MG = diaphragm size

Actuator version 1A with PTFE diaphragm can be used up to max. 4 bar. At temperatures above 30 °C the maximum operating pressure decreases.

The pressure rating (PN) depends on the diaphragm size.

Data for extended temperature ranges on request. Please note that the ambient temperature and media temperature generate a combined temperature at the valve body which must not exceed the above values.

Depending on the valve configuration, the maximum operating pressure of the pressure rating may be lower.

Observe the operating pressure table.

Kv values:

MG	Nominal size	Kv value
MG 10	DN 12	2.8
	DN 15	3.5
	DN 20	3.5
MG 20	DN 15	6.0
	DN 20	10.0
	DN 25	12.0
MG 25	DN 32	20.0
MG 40	DN 40	42.0
	DN 50	46.0

Kv values in m³/h

MG = diaphragm size

Kv values determined acc.to DIN EN 60534 standard, inlet pressure 5 bar, Δp 1 bar, PVC-U valve body and soft elastomer diaphragm.

The Kv values for other product configurations (e.g. other diaphragm or body materials) may differ. In general, all diaphragms are subject to the influences of pressure, temperature, the process and their tightening torques. Therefore the Kv values may exceed the tolerance limits of the standard.

The Kv value curve (Kv value dependent on valve stroke) can vary depending on the diaphragm material and duration of use.

Product compliance

Machinery Directive:	2006/42/EC
Pressure Equipment Directive:	2014/68/EU FDA* * depending on version and/or operating parameters
EMC Directive:	2014/30/EU
RoHS Directive:	2011/65/EU

Materials

Materials:

Diaphragm material	O-ring material
PTFE	FKM
NBR	EPDM
FKM	FKM
EPDM	EPDM

Mechanical data

Protection class: IP 65 acc. to EN 60529

Actuating speed: Actuator size 0 Max. 3 mm/s
 Actuator size 1 max. 2.5 mm/s
 Max. 3 mm/s

Weight: **Actuator**
 Actuator size 0 (code 0C) 0.95 kg
 Actuator size 1 (code 1A) 1.88 kg

Valve body

MG	DN	Spigot			Union end				Flange	Threaded socket	Solvent cement socket	Flare
		Connection type code										
		0, 30	20	28	3P, 7, 7R	33	3M, 3T	78	4, 39	1	2	75
10	12	-	-	-	-	-	-	-	-	0.08	0.06	-
	15	-	-	0.13	0.18	0.13	-	0.20	-	-	-	0.08
	20	-	-	-	-	-	-	-	-	-	-	0.125
20	15	0.12	0.10	-	0.17	0.24	0.26	0.27	0.67	-	-	-
	20	0.13	0.12	-	0.21	0.28	0.30	0.36	0.84	-	-	-
	25	0.16	0.14	-	0.26	0.33	0.38	0.37	1.28	-	-	-
25	32	0.22	0.18	-	0.40	0.70	0.73	0.63	1.89	-	-	-
40	40	0.50	0.40	-	0.73	0.83	0.93	1.13	2.36	-	-	-
	50	0.57	0.47	-	1.00	1.40	1.50	1.60	3.08	-	-	-

MG = diaphragm size, weight in kg

Installation position: Optional

Flow direction: Optional

Actuator duty cycle and service life

Service life: **Control operation** - Class C according to EN 15714-2 (1,800,000 starts and 1200 starts per hour).
Open/Close duty - At least 500,000 switching cycles at room temperature and permissible duty cycle.

Duty cycle: Control module Open/Close control (code AE, A5, A6)
 Duty cycle with full valve lift and playing time 10 minutes.

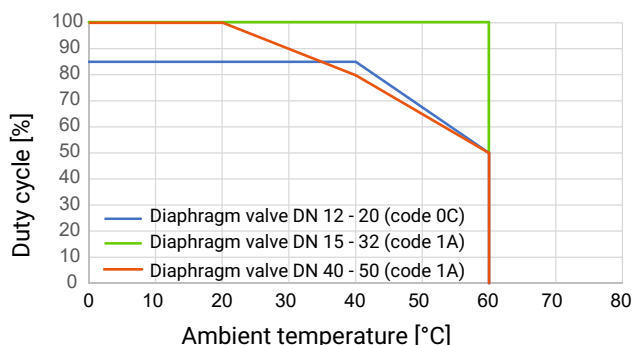

The specified characteristics and values apply to the default setting.

With reduced forces, higher duty cycles and/or higher ambient temperatures are possible. At higher force settings the duty cycle and/or ambient temperature is reduced (for IO-Link parameters see operating instructions).

Control module Positioner (code S0, S5, S6), Open/Close duty

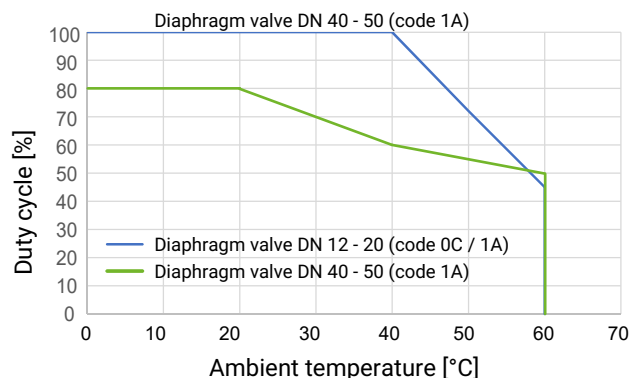

Control module positioner (code S0, S5, S6), control operation - class C acc. to EN 15714-2

- DN 4 - 25 (code 0A) up to 50 °C ambient temperature
- DN 40 - 50 (code 1A) up to 30 °C ambient temperature

Electrical data

Supply voltage Uv:	24 V DC \pm 10%	
Rating:	Actuator size 0 (code 0C)	20 W
	Actuator size 1 (code 1A)	60 W
Operation:	Stepper motor, self-locking	
Reverse battery protection:	Yes	

Analogue input signals – Control module Positioner (code S0, S5, S6)

Set value

Input signal:	0/4 - 20 mA; 0 - 10 V (function selectable via IO-Link)	
Input type:	passive	
Input resistance:	250 Ω	
Accuracy/linearity:	$\leq \pm 0.3\%$ of full flow	
Temperature drift:	$\leq \pm 0.1\%$ / 10°K	
Resolution:	12 bit	
Reverse battery protection:	Yes (up to \pm 24 V DC)	

Digital input signals

Inputs:	Function selectable via IO-Link (see table Overview of available functions – Input and output signals)	
Input voltage:	24 V DC	
Logic level "1":	> 15.3 V DC	
Logic level "0":	< 5.8 V DC	
Input current:	typically < 0.5 mA	

Analogue output signals – Control module Positioner (code S0, S5, S6)

Actual value

Output signal:	0/4 - 20 mA; 0 - 10 V (function selectable via IO-Link)	
Output type:	Active	
Accuracy:	$\leq \pm 1\%$ of full flow	
Temperature drift:	$\leq \pm 0.1\%$ / 10°K	
Load resistor:	≤ 750 k Ω	
Resolution:	12 bit	
Short-circuit proof:	Yes	

Digital output signals

Outputs:	Function selectable via IO-Link (see table Overview of available functions – Input and output signals)
Type of contact:	Push-Pull
Switching voltage:	Power supply U_v
Switching current:	≤ 140 mA
Short-circuit proof:	Yes

Communication

Interface:	IO-Link
Function:	Parameterization/process data
Transmission rate:	38400 baud
Frame type in Operate:	2.5 (eSyStep ON/OFF, code AE, A5, A6) 2.V (eSyStep positioner, code S0, S5, S6), PDout 3Byte; PDin 3 Byte; OnRequestData 2 Byte
Min. cycle time:	2.3 ms (eSyStep ON/OFF, code AE, A5, A6) 20 ms (eSyStep positioner, code S0, S5, S6)
Vendor-ID:	401
Device-ID:	1906701 (eSyStep ON/OFF, code AE, A5, A6) 1906801 (eSyStep positioner, code S0, S5, S6),
Product-ID:	eSyStep On/Off (code AE, A5, A6) eSyStep Positioner (code S0, S5, S6)
ISDU support:	Yes
SIO operation:	Yes
IO-Link specification:	V1.1

IODD files can be downloaded via <https://ioddfinder.io-link.com/> or www.gemu-group.com.

Electrical connection

Position of the connectors

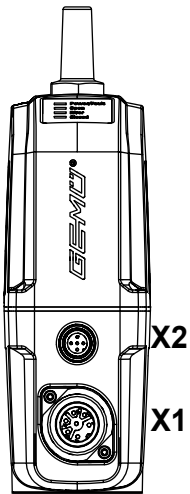

Electrical connection

Connection X1

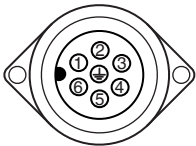

7-pin plug, Binder, type 693

Pin	Signal name
1	Uv, 24 V DC supply voltage
2	GND
3	Digital input 1
4	Digital input 2
5	Digital input/output
6	Digital output, IO-Link
7	n.c.

Connection X2 (only for positioner design)

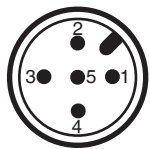

5-pin M12 plug, A-coded

Pin	Signal name
1	I+/U+, set value input
2	I-/U-, set value input
3	I+/U+, actual value output
4	I-/U-, actual value output
5	n.c.

Dimensions

Installation and actuator dimensions

Actuator version code 0C

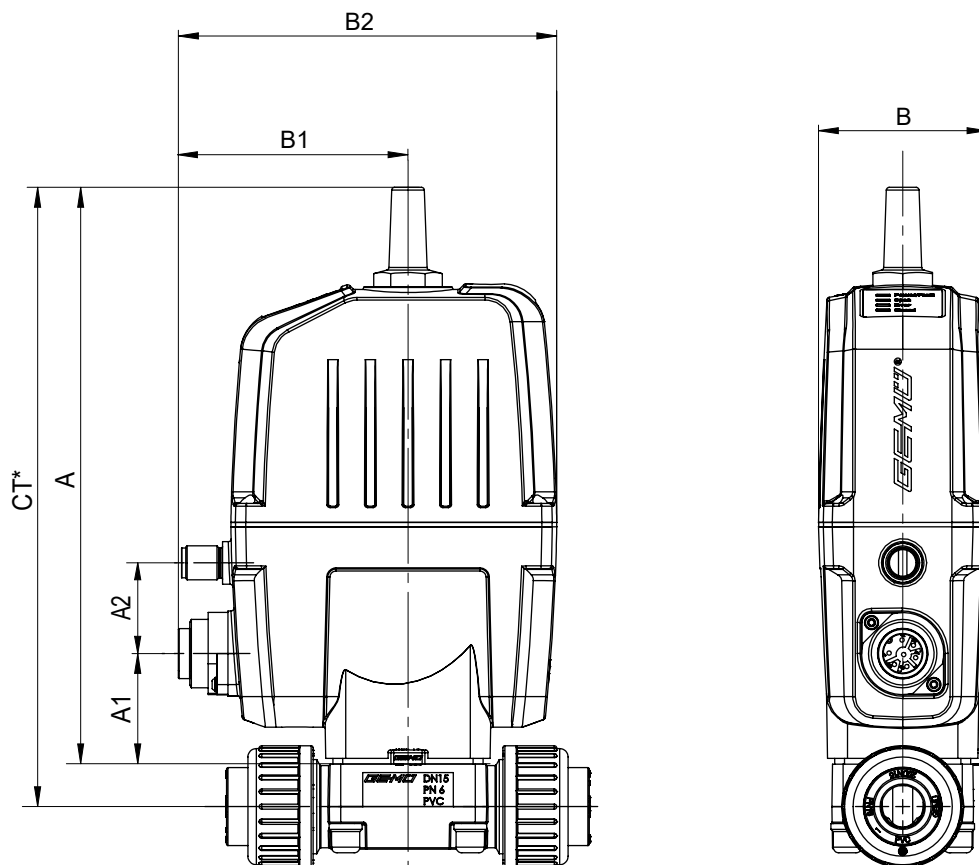

MG	DN	Actuator version	A	A1	A2	B	B1	B2
10	12 - 20	0C	203.5	39.0	33.2	59.4	81.0	133.5

Dimensions in mm

MG = diaphragm size

Dimension A2 only for control module – positioner (code S0, S5, S6)

* CT = A + H1 (see body dimensions)

Actuator version code 1A

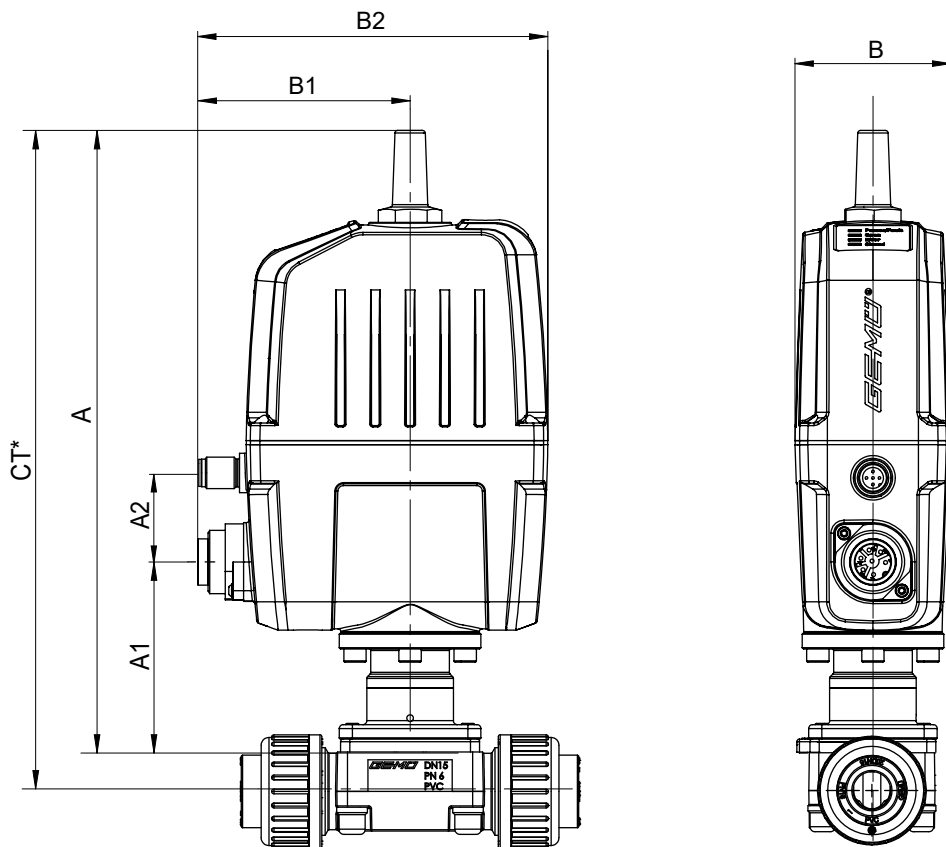

MG	DN	Actuator version	A	A1	A2	B	B1	B2
20	15 - 25	1A	298.0	116.0	32.5	70.0	82.0	150.0
25	32	1A	306.0	124.0	32.5	70.0	82.0	150.0
40	40 - 50	1A	304.0	122.0	32.5	70.0	82.0	150.0

Dimensions in mm

MG = diaphragm size

Dimension A2 only for control module – positioner (code S0, S5, S6)

* CT = A + H1 (see body dimensions)

Body dimensions

Spigot DIN / inch (code 0, 30)

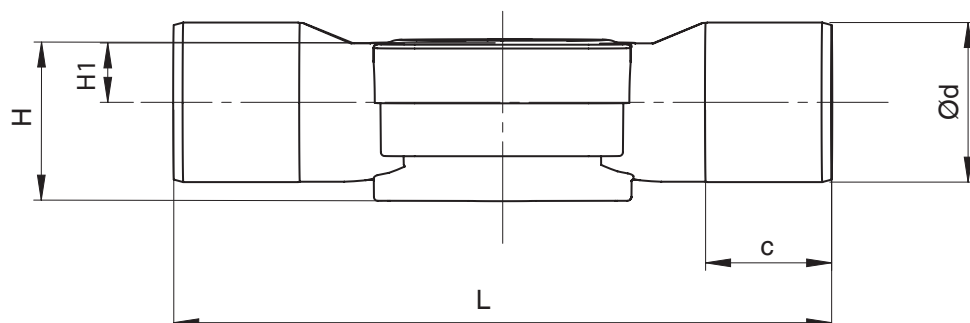

Connection type spigot DIN (code 0)¹⁾, body material PVC-U (code 1), inliner/outliner (code 71, 75)²⁾

MG	DN	NPS	c		ød	H		H1	L
			Material			Material			
			1	71, 75		1	71, 75		
20	15	1/2"	16.0	18.0	20.0	36.0	36.0	10.0	124.0
	20	3/4"	19.0	19.0	25.0	38.0	38.0	12.0	144.0
	25	1"	22.0	22.0	32.0	39.0	39.0	13.0	154.0
25	32	1 1/4"	32.0	32.0	40.0	41.0	41.0	15.0	174.0
40	40	1 1/2"	35.0	26.0	50.0	63.2	63.2	23.2	194.0
	50	2"	38.0	33.0	63.0	63.2	63.2	23.2	224.0

Connection type spigot – inch (code 30)¹⁾, body material PVC-U (code 1), ABS (code 4)²⁾

MG	DN	NPS	c	ød	H	H1	L
20	15	1/2"	24.0	21.4	36.0	10.0	141.0
	20	3/4"	27.0	26.7	38.0	12.0	144.0
	25	1"	30.0	33.6	39.0	13.0	154.0
25	32	1 1/4"	33.0	42.2	41.0	15.0	174.0
40	40	1 1/2"	35.0	48.3	63.2	23.2	194.0
	50	2"	40.0	60.3	63.2	23.2	224.0

Dimensions in mm

MG = diaphragm size

1) Connection type

Code 0: Spigot DIN

Code 30: Spigot – inch, for welding or solvent cementing, depending on the body material

2) Valve body material

Code 1: PVC-U, grey

Code 4: ABS

Code 71: Inliner PP-H, grey, outliner PP, reinforced

Code 75: Inliner PVDF/outliner PP, reinforced

Spigot IR (code 20)

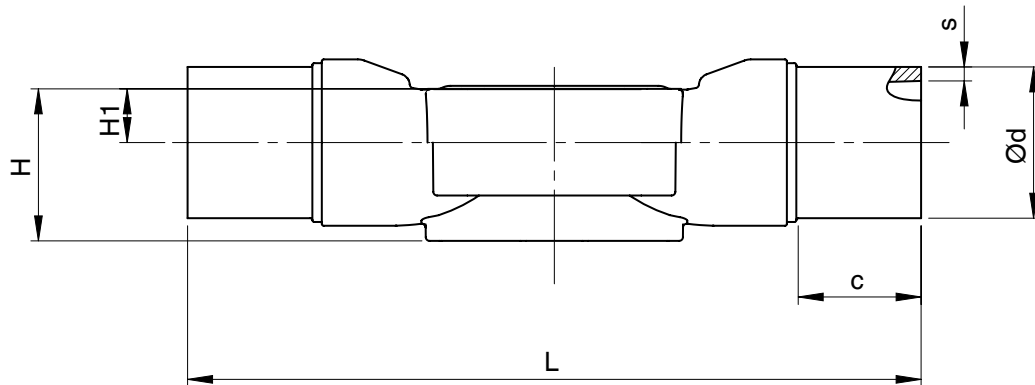

Connection type spigot IR (code 20)¹⁾, body material inliner/outliner (code 71, 75)²⁾

MG	DN	NPS	c	Ød	H	H1	L	s	
								Material	
								71	75
20	15	1/2"	33.0	20.0	36.0	10.0	154.0	1.9	1.9
	20	3/4"	33.0	25.0	38.0	12.0	154.0	2.3	1.9
	25	1"	33.0	32.0	39.0	13.0	154.0	2.9	2.4
25	32	1¼"	33.0	40.0	41.0	15.0	194.0	3.7	2.4
40	40	1½"	33.0	50.0	63.2	23.2	194.0	4.6	3.0
	50	2"	33.0	63.0	63.2	23.2	224.0	5.8	3.0

Dimensions in mm

MG = diaphragm size

1) **Connection type**

Code 20: Spigot for IR butt welding

2) **Valve body material**

Code 71: Inliner PP-H, grey, outliner PP, reinforced

Code 75: Inliner PVDF/outliner PP, reinforced

Spigot (code 28)

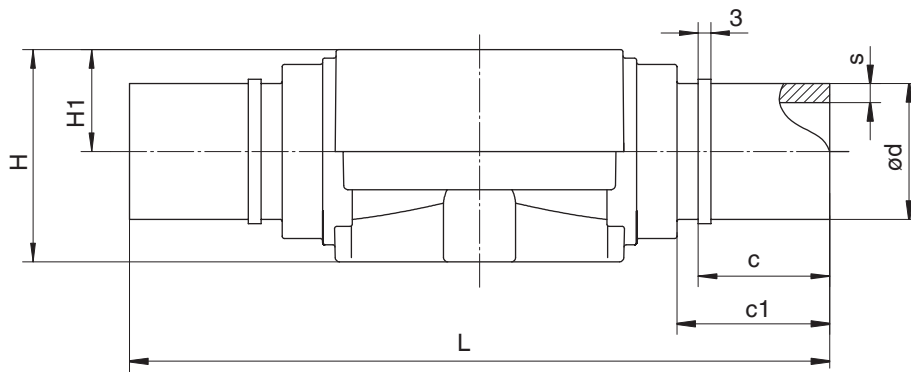

Connection type spigot (code 28)¹⁾, body material PVDF (code 20)²⁾

MG	DN	NPS	c	c1	ød	H	H1	L	s
10	15	1/2"	31.0	37.0	20.0	41.0	16.0	134.0	1.9

Dimensions in mm

MG = diaphragm size

1) Connection type

Code 28: Spigot for IR butt welding, BCF

2) Valve body material

Code 20: PVDF

Union end DIN (code 7)

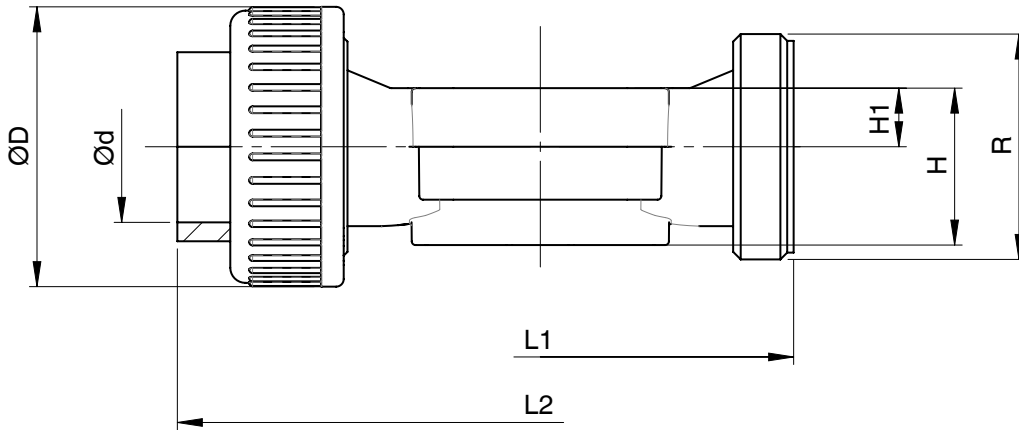

Connection type union end DIN (code 7)¹⁾, body material PVC-U (code 1), PP (code 5), PVDF (code 20), PP-H (code N5)²⁾, diaphragm size 10

MG	DN	NPS	ød	øD	H		H1		L1	L2		R
					Material		Material			Material		
					1, 20	5, N5	1, 20	5, N5		1, 20	5, N5	
10	15	1/2"	20.0	43.0	30.0	41.0	15.0	16.0	90.0	128.0	125.0	G 1

Connection type union end DIN (code 7)¹⁾, body material PVC-U (code 1), ABS (code 4), inliner/outliner (code 71, 75)²⁾, diaphragm size 20 – 40

MG	DN	NPS	ød	øD	H	H1	L1	L2				R
								Material				
								1	4	71	75	
20	15	1/2"	20.0	43.0	36.0	10.0	108.0	146.0	150.0	143.0	146.0	G 1
	20	3/4"	25.0	53.0	38.0	12.0	108.0	152.0	156.0	146.0	150.0	G 1¼
	25	1"	32.0	60.0	39.0	13.0	116.0	166.0	170.0	158.0	162.0	G 1½
25	32	1¼"	40.0	74.0	41.0	15.0	134.0	192.0	196.0	181.0	184.0	G 2
40	40	1½"	50.0	83.0	63.2	23.2	154.0	222.0	222.0	207.0	210.0	G 2¼
	50	2"	63.0	103.0	63.2	23.2	184.0	266.0	266.0	245.0	248.0	G 2¾

Dimensions in mm

MG = diaphragm size

1) **Connection type**

Code 7: Union end with insert (socket) – DIN

2) **Valve body material**

Code 1: PVC-U, grey

Code 4: ABS

Code 5: PP, reinforced

Code 20: PVDF

Code 71: Inliner PP-H, grey, outliner PP, reinforced

Code 75: Inliner PVDF/outliner PP, reinforced

Code N5: PP-H, natural

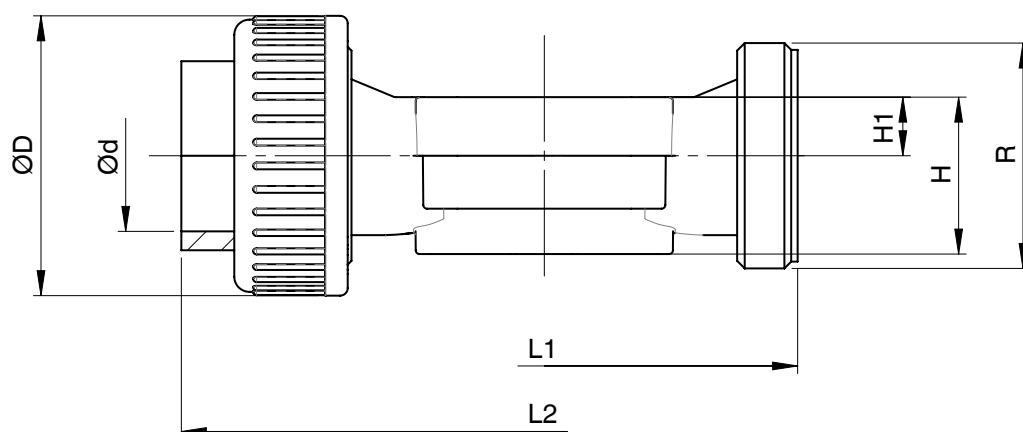
Union end inch (code 33, 3M, 3T)**Connection type union end inch (code 33)¹⁾, body material PVC-U (code 1)²⁾, diaphragm size 10**

MG	DN	NPS	ød	øD	H	H1	L1	L2	R
10	15	1/2"	21.4	43.0	30.0	15.0	90.0	128.0	G1

Connection type union end inch (code 33, 3M, 3T)¹⁾, body material PVC-U (code 1)²⁾, diaphragm sizes 20 - 40

MG	DN	NPS	ød			øD		H	H1	L1	L2			R	
			Connection type								Connection type				
			33	3M	3T	33, 3M	3T				33	3M	3T	33, 3M	3T
20	15	1/2"	21.4	21.4	22.0	43.0	53.0 *	36.0	10.0	108.0	146.0	158.0	152.0	G 1	G 1¼ *
	20	3/4"	26.8	26.7	26.0	53.0	53.0	38.0	12.0	108.0	152.0	164.0	152.0	G 1¼	G 1¼
	25	1"	33.6	33.5	32.0	60.0	60.0	39.0	13.0	116.0	166.0	180.0	166.0	G 1½	G 1½
25	32	1¼"	42.3	42.2	38.0	74.0	74.0	41.0	15.0	134.0	192.0	204.0	192.0	G 2	G 2
40	40	1½"	48.3	48.3	48.0	83.0	83.0	63.2	23.2	154.0	222.0	230.0	222.0	G 2¼	G 2¼
	50	2"	60.4	60.4	60.0	103.0	103.0	63.2	23.2	184.0	264.0	266.0	266.0	G 2¾	G 2¾

Connection type BS (code 33)¹⁾, body material ABS (code 4)²⁾

MG	DN	NPS	ød	øD	H	H1	L1	L2	R
20	15	1/2"	21.4	43.0	36.0	10.0	108.0	150.0	G 1
	20	3/4"	26.8	53.0	38.0	12.0	108.0	156.0	G 1¼
	25	1"	33.6	60.0	39.0	13.0	116.0	170.0	G 1½
25	32	1¼"	42.3	74.0	41.0	15.0	134.0	198.0	G 2
40	40	1½"	48.3	83.0	63.2	23.2	154.0	220.0	G 2¼
	50	2"	60.4	103.0	63.2	23.2	184.0	264.0	G 2¾

Dimensions in mm

MG = diaphragm size

* Insert requires valve body DN 20

1) Connection type

Code 33: Union end with inch insert – BS (socket)

Code 3M: Union end with inch insert – ASTM (socket)

Code 3T: Union end with insert – JIS (socket)

2) Valve body material

Code 1: PVC-U, grey

Code 4: ABS

Union end DIN, IR butt welding (code 78)

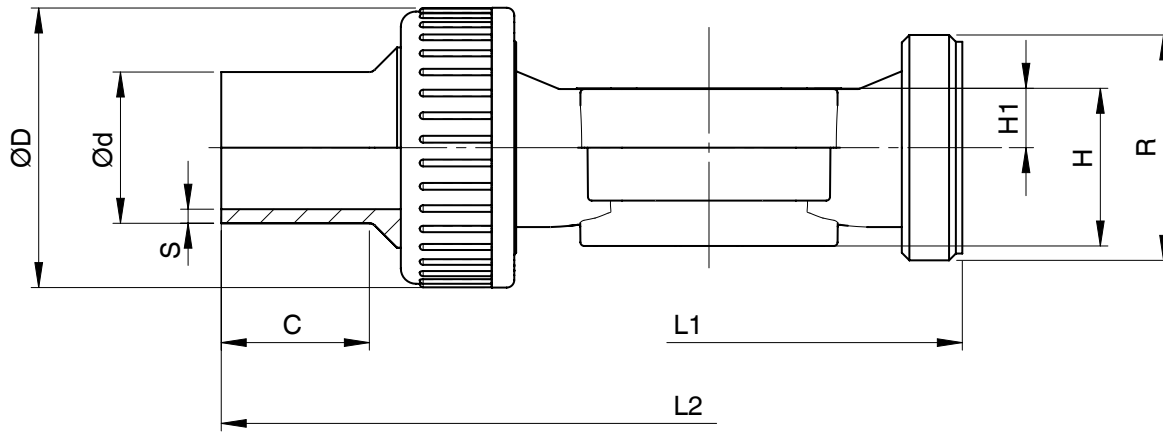

Connection type union end DIN, IR butt welding (code 78)¹⁾, body materials PP (code 5), PVDF (code 20), PP-H (code N5)²⁾

MG	DN	NPS	c	ød	øD	H		H1		L1	L2	R	s
						Material		Material					
						5	20, N5	5	20, N5				
10	15	1/2"	36.0	20.0	42.0	30.0	41.0	15.0	16.0	90.0	196.0	G 1	1.9

Connection type union end DIN, IR butt welding (code 78)¹⁾, body material inliner/outliner (code 71, 75)²⁾

MG	DN	NPS	c	ød	øD	H	H1	L1	L2	R	s	
											Material	
											71	75
20	15	1/2"	36.0	20.0	43.0	36.0	10.0	108.0	214.0	G 1	1.9	1.9
	20	3/4"	37.0	25.0	53.0	38.0	12.0	108.0	220.0	G 1¼	2.3	1.9
	25	1"	39.0	32.0	60.0	39.0	13.0	116.0	234.0	G 1½	2.9	2.4
25	32	1¼"	39.0	40.0	74.0	41.0	15.0	134.0	258.0	G 2	3.7	2.4
40	40	1½"	43.0	50.0	83.0	63.2	23.2	154.0	284.0	G 2¼	4.6	3.0
	50	2"	43.0	63.0	103.0	63.2	23.2	184.0	320.0	G 2¾	5.8	3.0

Dimensions in mm

MG = diaphragm size

1) **Connection type**

Code 78: Union end with insert (for IR butt welding) – DIN

2) **Valve body material**

Code 5: PP, reinforced

Code 20: PVDF

Code 71: Inliner PP-H, grey, outliner PP, reinforced

Code 75: Inliner PVDF/outliner PP, reinforced

Code N5: PP-H, natural

Fitting screw connection Rp (Code 7R), NPT (Code 3P)

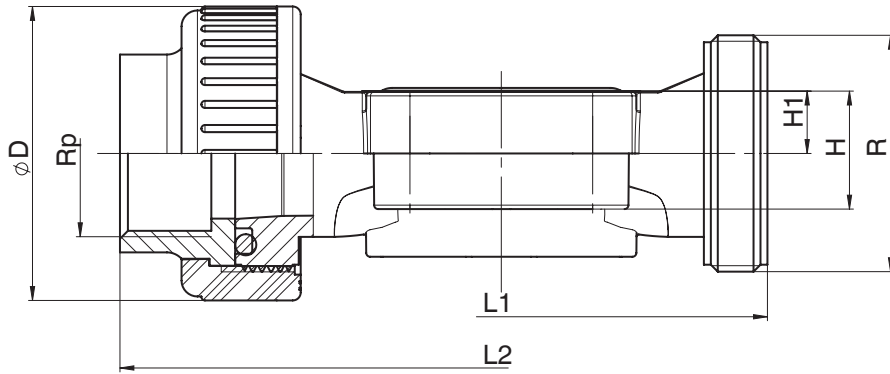

Connection type union end Rp (code 7R), NPT (code 3P)¹⁾, body material PVC-U (code 1)²⁾

MG	DN	NPS	øD	H	H1	L1	L2	R	Rp/NPT
20	15	1/2"	43.0	36.0	10.0	108.0	146.0	G 1	1/2
	20	3/4"	53.0	38.0	12.0	108.0	152.0	G 1¼	3/4
	25	1"	60.0	39.0	13.0	116.0	166.0	G 1½	1
25	32	1¼"	74.0	41.0	15.0	134.0	192.0	G 2	1¼
40	40	1½"	83.0	63.2	23.2	154.0	222.0	G 2¼	1½
	50	2"	103.0	63.2	23.2	184.0	266.0	G 2¾	2

Dimensions in mm

- 1) **Connection type**
Code 7R: Union end with insert (Rp threaded socket) – DIN
Code 3P: Union end with insert (NPT threaded socket)
- 2) **Valve body material**
Code 1: PVC-U, grey

Threaded socket (code 1)

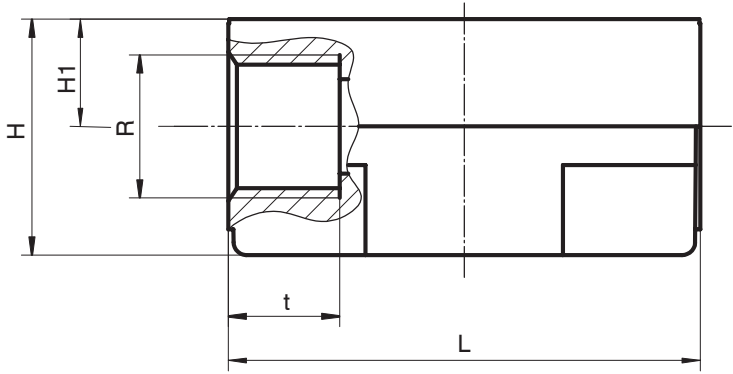

Connection type threaded socket (code 1)¹⁾, body materials PVC-U (code 1), PP (code 5), PVDF (code 20)²⁾

MG	DN	NPS	H		H1	L	R	t
			Material					
			1, 5	20				
10	12	3/8"	27.5	31.5	12.5	55.0	G3/8	13.0

Dimensions in mm

MG = diaphragm size

1) **Connection type**

Code 1: Threaded socket DIN ISO 228

2) **Valve body material**

Code 1: PVC-U, grey

Code 5: PP, reinforced

Code 20: PVDF

Solvent cement socket (code 2)

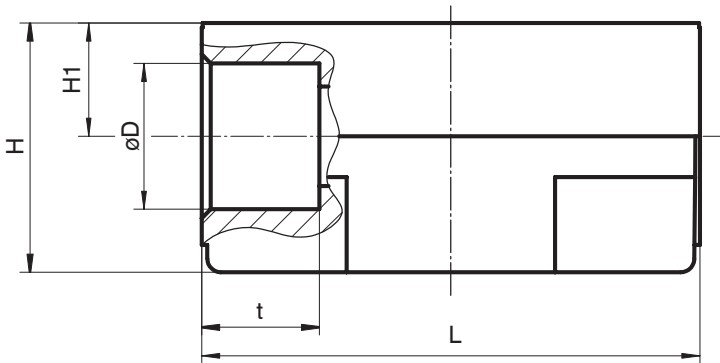

Connection type solvent cement socket (code 2)¹⁾, body material PVC-U (code 1)²⁾

MG	DN	NPS	ø D	H	H1	L	t
10	12	3/8"	16.0	27.5	12.5	55.0	13.0

Dimensions in mm

MG = diaphragm size

1) **Connection type**

Code 2: Solvent cement socket DIN

2) **Valve body material**

Code 1: PVC-U, grey

Flange EN (code 4)

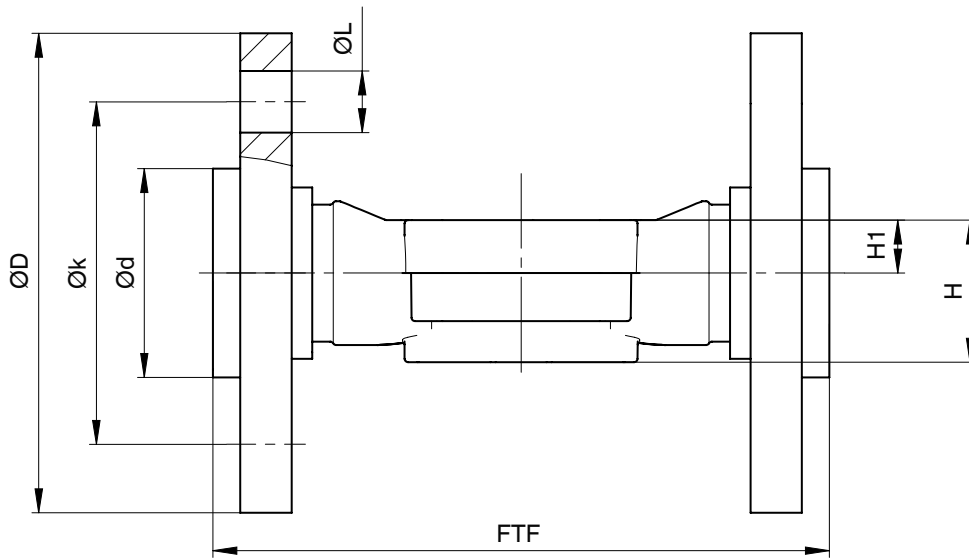

Connection type flange EN (code 4)¹⁾, body materials PVC-U (code 1)²⁾

MG	DN	NPS	ød	øD	FTF	H	H1	øk	øL	n
20	15	1/2"	34.0	95.0	130.0	36.0	10.0	65.0	14.0	4
	20	3/4"	41.0	105.0	150.0	38.0	12.0	75.0	14.0	4
	25	1"	50.0	115.0	160.0	39.0	13.0	85.0	14.0	4
25	32	1¼"	61.0	140.0	180.0	41.0	15.0	100.0	18.0	4
40	40	1½"	73.0	150.0	200.0	63.2	23.2	110.0	18.0	4
	50	2"	90.0	165.0	230.0	63.2	23.2	125.0	18.0	4

Connection type flange EN (code 4)¹⁾, body material inliner/outliner (code 71, 75)²⁾

MG	DN	NPS	ød	øD	FTF	H	H1	øk	øL	n
20	15	1/2"	45.0	95.0	130.0	36.0	10.0	65.0	14.0	4
	20	3/4"	58.0	105.0	150.0	38.0	12.0	75.0	14.0	4
	25	1"	68.0	115.0	160.0	39.0	13.0	85.0	14.0	4
25	32	1¼"	78.0	140.0	180.0	41.0	15.0	100.0	18.0	4
40	40	1½"	88.0	150.0	200.0	63.2	23.2	110.0	18.0	4
	50	2"	102.0	165.0	230.0	63.2	23.2	125.0	18.0	4

Dimensions in mm

MG = diaphragm size

n = number of bolts

1) Connection type

Code 4: Flange EN 1092, PN 10, form B, face-to-face dimension FTF EN 558 series 1, ISO 5752, basic series 1

2) Valve body material

Code 1: PVC-U, grey

Code 71: Inliner PP-H, grey, outliner PP, reinforced

Code 75: Inliner PVDF/outliner PP, reinforced

Flange ANSI (code 39)

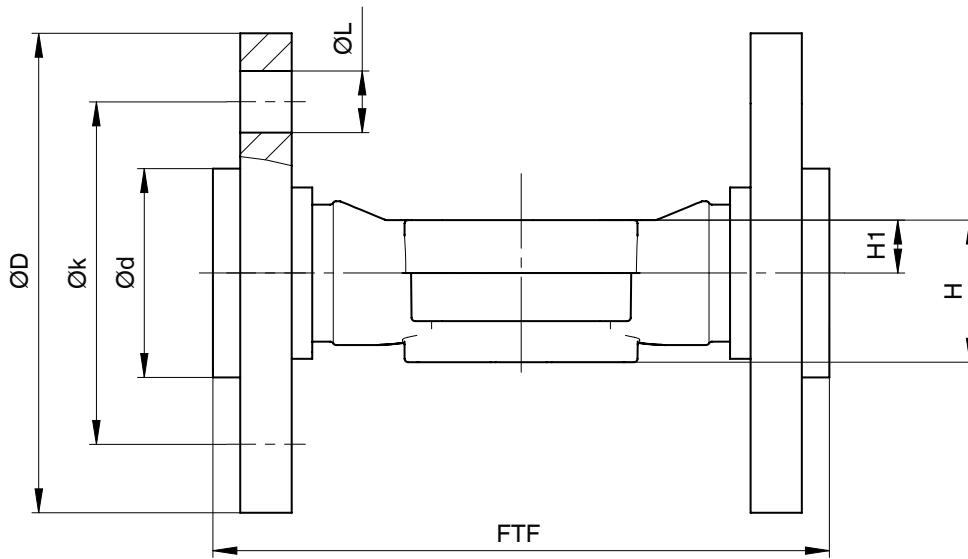

Connection type flange ANSI (code 39)¹⁾, body material PVC-U (code 1)²⁾

MG	DN	NPS	ød	øD	FTF	H	H1	øk	øL	n
20	15	1/2"	34.0	95.0	130.0	36.0	10.0	60.0	16.0	4
	20	3/4"	41.0	105.0	150.0	38.0	12.0	70.0	16.0	4
	25	1"	50.0	115.0	160.0	39.0	13.0	79.0	16.0	4
25	32	1¼"	61.0	140.0	180.0	41.0	15.0	89.0	16.0	4
40	40	1½"	73.0	150.0	200.0	63.2	23.2	98.0	16.0	4
	50	2"	90.0	165.0	230.0	63.2	23.2	121.0	19.0	4

Connection type flange ANSI (code 39)¹⁾, body material inliner/outliner (code 71, 75)²⁾

MG	DN	NPS	ød	øD	FTF	H	H1	øk	øL	n
20	15	1/2"	45.0	95.0	130.0	36.0	10.0	60.0	16.0	4
	20	3/4"	54.0	105.0	150.0	38.0	12.0	70.0	16.0	4
	25	1"	63.0	115.0	160.0	39.0	13.0	79.0	16.0	4
25	32	1¼"	73.0	140.0	180.0	41.0	15.0	89.0	16.0	4
40	40	1½"	82.0	150.0	200.0	63.2	23.2	98.0	16.0	4
	50	2"	102.0	165.0	230.0	63.2	23.2	121.0	19.0	4

Dimensions in mm

MG = diaphragm size

n = number of bolts

1) Connection type

Code 39: Flange ANSI Class 125/150 RF, face-to-face dimension FTF EN 558 series 1, ISO 5752, basic series 1, length only for body configuration D

2) Valve body material

Code 1: PVC-U, grey

Code 71: Inliner PP-H, grey, outliner PP, reinforced

Code 75: Inliner PVDF/outliner PP, reinforced

Flare (code 75)

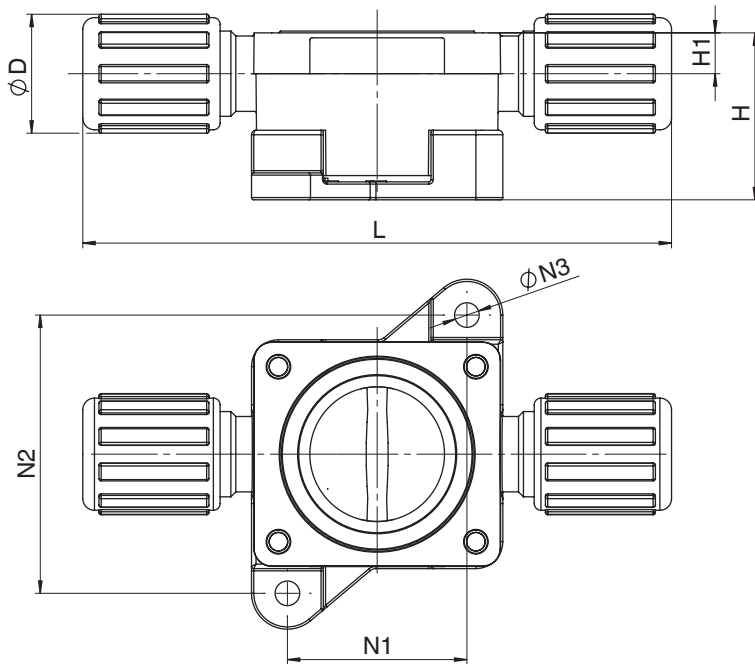

Connection type flare (code 75) ¹⁾, body material PP-H (code N5) ²⁾

MG	DN	NPS	ϕD	H	H1	L	N1	N2	$\phi N3$
10	15	1/2"	26.5	38.1	10.0	132.0	40.0	62.0	5.5
	20	3/4"	26.5	44.5	15.0	134.0	40.0	62.0	5.5

Dimensions in mm
MG = diaphragm size

- 1) **Connection type**
Code 75: Flare connection with PVDF union nut
- 2) **Valve body material**
Code N5: PP-H, natural

Valve body mounting

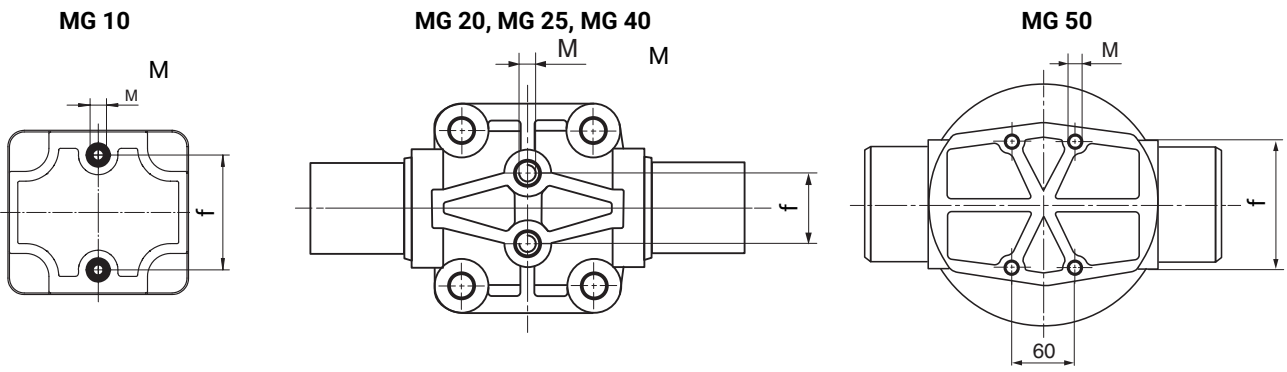

Diaphragm size	Nominal size	M	f
10	10 - 20	M5	35.0
20	15 - 25	M6	25.0
25	32	M6	25.0
40	40, 50	M8	44.5

Dimensions in mm
 MG = diaphragm size

Mounting plate

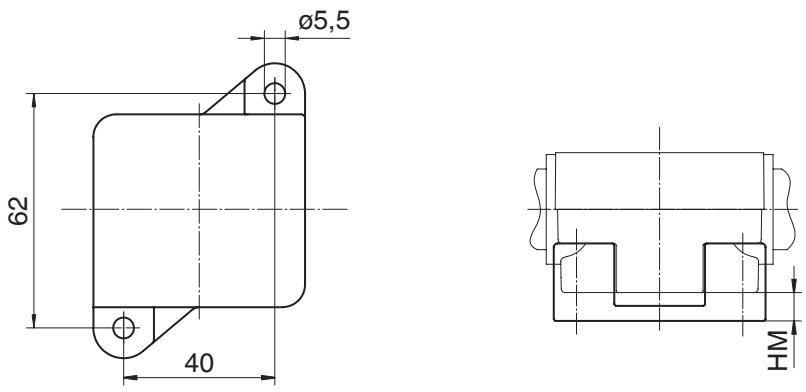

MG	DN	HM
10	12	5.0
	15	4.5
	20	4.5

Dimensions in mm, MG = diaphragm size

Accessories



GEMÜ 1218

Connector

The GEMÜ 1218 is a connector (cable socket / cable plug), 7-pin. Straight and/or 90° angled plug type.

GEMÜ 1218 Binder connector			
Connection X1 – supply voltage, relay outputs			
Binder plug	468/eSy series mating connector	Terminal compartment/ screws, 7-pin	88220649 ¹⁾
		Terminal compartment/ screws, 7-pin, 90°	88377714
		Terminal compartment/ screws, 7-pin, 90°, fitted with a 2 metre cable set	88770522

1) provided in the scope of delivery



GEMÜ 1219

Cable socket / cable plug M12

The GEMÜ 1219 is a connector (cable socket / cable plug) M12, 5-pin. Straight and/or 90° angled plug type. Defined cable length or with threaded connection without cable. Various materials available for the threaded ring.

Suitable for electrical connection of the connector X2

Description	Length	Order number
5-pin, angle	without cable	88205545 ¹⁾
	2 m cable	88205534
	5 m cable	88205540
	10 m cable	88210911
	15 m cable	88244667
5-pin, straight	without cable	88205544
	2 m cable	88205542
	5 m cable	88205543
	10 m cable	88270972
	15 m cable	88346791

1) provided in the scope of delivery for control module code S0



GEMÜ 1560

IO-Link master

The GEMÜ 1560 IO-Link master is used for parametrization, actuation, commissioning and for evaluating process and diagnostics data on products with IO-Link interface with communication standard in accordance with IEC 61131-9. The IO-Link master is available with USB port for use on a computer or with a Bluetooth or WLAN interface for use on mobile devices (iOS and Android). GEMÜ 1560 can be ordered separately or as a set for GEMÜ products including the required adapter.

Description	Order designation	Order number
IO-Link master kit (adapter plus cable)	1560USBS 1 A40A12AU A	99072365
IO-Link master kit (adapter plus cable)	1560 BTS 1 A20A12AA A	99130458



GEMÜ 1571

Emergency power supply module

The GEMÜ 1571 capacitive emergency power supply module is suitable for valves with motorized actuators such as GEMÜ eSyStep and eSyDrive as well as the GEMÜ C53 iComLine control valve. In the event of a power failure, the product provides an uninterrupted power supply so that the valve can be moved to the safety position. The emergency power supply module is available individually or with an expansion module and can supply several valves. The input and output voltage is 24 V.

GEMÜ 1571 emergency power supply module			
Input voltage	Output voltage	Capacity	Item number
24 V	24 V	1700 Ws	88660398
24 V	24 V	13200 Ws	88751062



GEMÜ 1573

Switching power supply unit

The GEMÜ 1573 switching power supply unit converts unstable input voltages from 100 to 240 V AC into a continuous DC voltage. It can be used as an accessory for valves with motorized actuators e. g. GEMÜ eSyLite, eSyStep und eSyDrive and for additional devices with a 24 V DC power supply. Different power levels, output currents and a 48 V DC version for servoDrive actuators are available.

GEMÜ 1573 switching power supply unit			
Input voltage	Output voltage	Output current	Item number
100 - 240 V AC	24 V DC	5 A	88660400
		10 A	88660401



GEMÜ Gebr. Müller Apparatebau GmbH & Co. KG
Fritz-Müller-Straße 6-8, 74653 Ingelfingen-Criesbach, Germany
Phone +49 (0) 7940 1230 · info@gemue.de
www.gemu-group.com