



Pneumatically actuated 2/2-way globe valve for decentralised automation

- For high-pressure applications up to 600 bar
- Long service life
- Requires a pressure difference
- High-quality materials
- Reliable, durable sealing elements



Product variants described in the data sheet may differ from the product presentation and description.

Can be combined with



Type 7012
Direct-acting 3/2-way plunger valve



Type 6014
Plunger valve 3/2-way direct-acting



Type description

The innovative Bürkert process on/off valve Type 2121 is the solution when it comes to shut-off tasks under demanding operating conditions. The servo-assisted piston valve is specifically designed for high-pressure applications and meets all hydrogen-related industry requirements. Maximum service life and tightness are ensured by the Dynamic Sealing Package, even under heavy load conditions. High-quality stainless steels and additional refinement processes make pressure-bearing, moving parts resistant to hydrogen embrittlement. Furthermore, the unique design allows for easy detection of leaks and escaping gases, providing an enhanced degree of safety.

Table of contents

1. General technical data	3
2. Control functions	4
3. Approvals and conformities	5
3.1. General notes	5
3.2. Conformity	5
3.3. Standards	5
3.4. Others	5
Hydrogen	5
4. Materials	5
4.1. Bürkert resistApp	5
5. Dimensions	6
5.1. Actuator	6
Aluminium actuator variant	6
Nickel-plated brass actuator variant	7
6. Ordering information	8
6.1. Bürkert eShop	8
6.2. Bürkert product filter	8
6.3. Bürkert Product Enquiry Form	8
6.4. Ordering chart	8
Valves with flow direction below seat	8

DTS 1000633110 EN Version: - Status: RL (released | freigegeben | validé) printed: 03.10.2024

1. General technical data

Product properties	
Dimensions	Further information can be found in chapter "4. Materials" on page 5.
Material	
Body	Stainless steel 1.4404
Seal	PEEK
Design	Piston seat valve
Nominal diameter	DN 13, DN 25, DN 40 and DN 50
Safety position in the event of power failure	Closed (control function A)
Flow direction	In closing direction (above seat)
Performance data	
Operating pressure	1...600 bar
Nominal pressure	PN 600
Pilot Pressure	4...10 bar
Tightness	
Permissible internal leakage rate	2×10^{-3} mbar l/s at 20 bar, 5×10^{-5} mbar l/s at nominal pressure
Permissible external leakage rate	5×10^{-5} mbar l/s
Max. switching cycles with regard to leakage rates	Ca. 50.000 at $\Delta p = 100...200$ bar
Max. absolute switching cycles (service)	Ca. 80.000 (1 year) at $\Delta p = 100...200$ bar
K_v value	3,8 m ³ /h...32,0 m ³ /h
Medium data	
Operating medium ¹⁾	Hydrogen
Medium temperature	- 40 °C...+ 80 °C
Viscosity	Max. 22 mm ² /s
Control medium	Clean, neutral gases
Approvals and conformities	
Further information can be found in chapter "3. Approvals and conformities" on page 5.	
Material certificate	2.2, 3.1
Process/Port connection & communication	
Port Connection	
Threaded connection	G 1/2, G 1, G 1 1/2, G 2
Pilot air port	G 1/8
Environment and installation	
Installation position	Upright or horizontal actuator
Ambient temperature	- 20 °C...+ 60 °C

1.) Media resistance according to the material combination

2. Control functions

⚠ CAUTION
Risk of injury due to bursting pipes and bursting appliance if the flow is above the seat. In the case of liquid media, a closing impact can cause pipes and the appliance to burst.
Do not use valves with flow direction above the seat for liquid media.

Symbol	Description
Flow direction under seat	
	Control function A (CF A) Pneumatically operated 2/2-way on/off valve Flow direction above seat Normally closed by spring force

3. Approvals and conformities

3.1. General notes

- The approvals and conformities listed below must be stated when making enquiries. This is the only way to ensure that the product complies with all required specifications.
- Not all available versions can be supplied with the below mentioned approvals or conformities.

3.2. Conformity

In accordance with the Declaration of Conformity, the product is compliant with the EU Directives.

- Pressure Equipment Directive 2014/68/E
- Machinery Directive 2006/42/EC

3.3. Standards

The applied standards which are used to demonstrate compliance with the EU Directives are listed in the EU-Type Examination Certificate and/or the EU Declaration of Conformity.

3.4. Others

Hydrogen

Conformity	Description
H₂	<p>Suitability for hydrogen</p> <p>The products are suitable for use with gaseous hydrogen, in accordance with the manufacturer's declaration.</p> <ul style="list-style-type: none"> • ISO 19880 - 3: Gaseous hydrogen - Refuelling stations - Part 3: Shut-off devices • SAE J2601: Fueling Protocols for Light Duty Gaseous Hydrogen Surface Vehicles → 700 bar • SAE J2601 - 2: Fueling Protocol for Gaseous Hydrogen Powered Heavy Duty Vehicles → 350 bar • ISO 14687: Characteristics of hydrogen as a fuel - Specification of the product • DIN 17124: Hydrogen as a fuel • SAE J2719: Hydrogen Purity

4. Materials

4.1. Bürkert resistApp

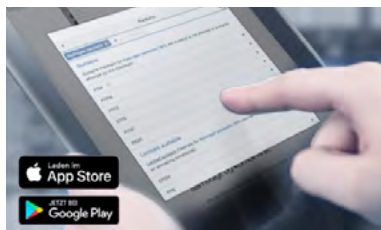

Bürkert resistApp – Chemical resistance chart

You want to ensure the reliability and durability of the materials in your individual application case? Verify your combination of media and materials on our website or in our resistApp.

[Start chemical resistance check](#)

5. Dimensions

5.1. Actuator

Aluminium actuator variant

Note:

Dimensions in mm

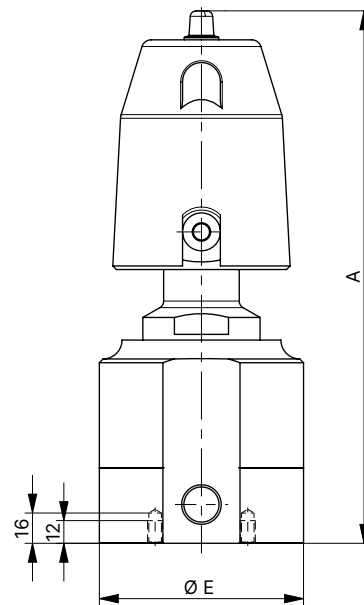
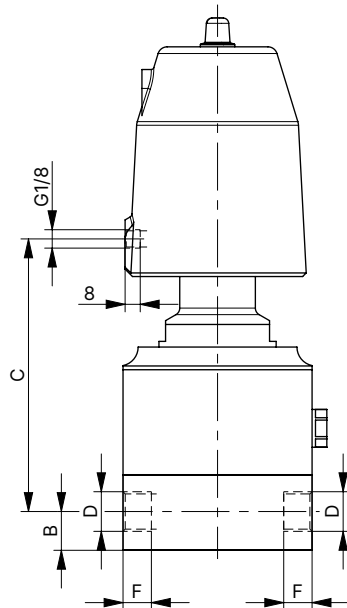
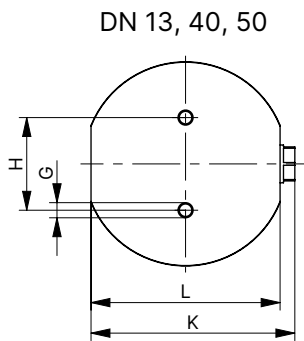
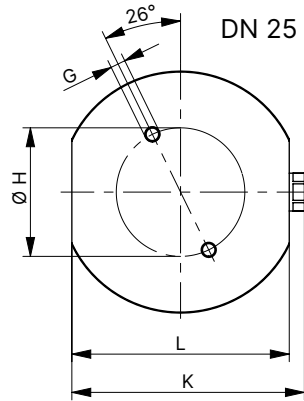

DN	A	B	C	D	Ø E	F	G	H	K	L
13	281.5	20.5	164.7	G ½	108	15	M8	49	107.8	100
25	309	24	191.4	G 1	128	18	M8	Ø 68	123	115
40	356	40	239.2	G 1 ½	169	22	M8	60	148	140
50	364	42	247.2	G 2	170	27	M12	120	177	155

Nickel-plated brass actuator variant

Note:

Dimensions in mm

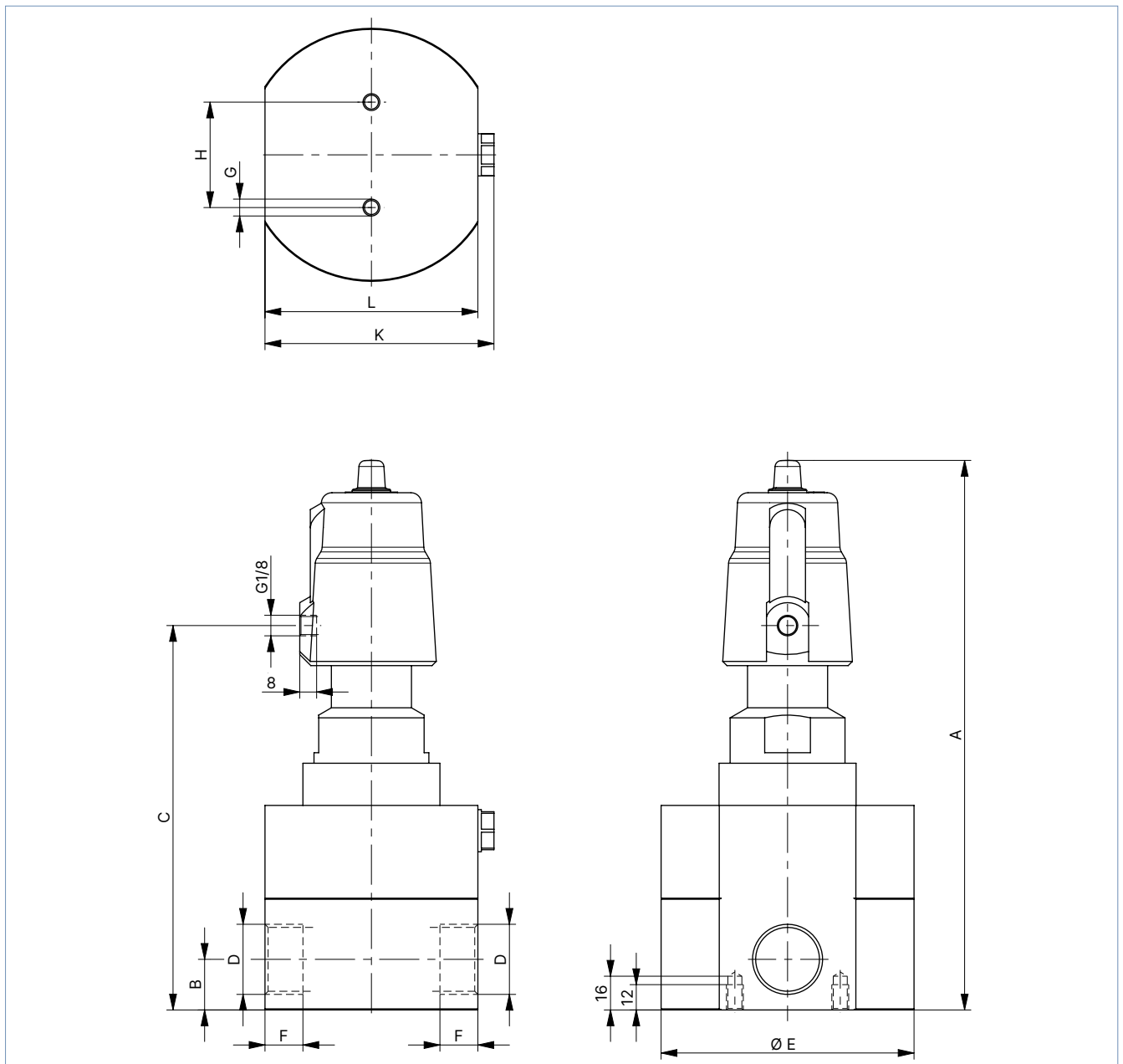

DN	A	B	C	D	Ø E	F	G	H	K	L
13	237	20.5	158.3	G ½	84	15	M8	30	90.5	78
25	261	24	182.3	G 1	120	18	M8	50	108.6	101
40	305.6	40	227.3	G 1 ½	159	22	M8	100	-	140
50	322.3	42	243.3	G 2	170	27	M12	120	176	155

DTS 1000633110 EN Version: - Status: RL (released | freigegeben | validé) printed: 03.10.2024

6. Ordering information

6.1. Bürkert eShop



Bürkert eShop – Easy ordering and quick delivery

You want to find your desired Bürkert product or spare part quickly and order directly? Our online shop is available for you 24/7. Sign up and enjoy all the benefits.

[Order online now](#)

6.2. Bürkert product filter

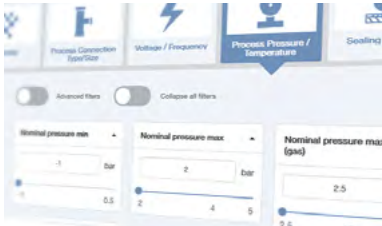

Bürkert product filter – Get quickly to the right product

You want to select products comfortably based on your technical requirements? Use the Bürkert product filter and find suitable articles for your application quickly and easily.

[Try out our product filter](#)

6.3. Bürkert Product Enquiry Form

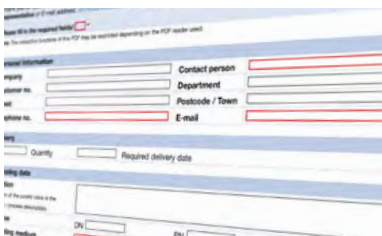

Bürkert Product Enquiry Form – Your enquiry quickly and compactly

Would you like to make a specific product enquiry based on your technical requirements? Use our Product Enquiry Form for this purpose. There you will find all the relevant information for your Bürkert contact. This will enable us to provide you with the best possible advice.

[Fill out the form now](#)

6.4. Ordering chart

Valves with flow direction below seat

Control function	Port Connection	Nominal diameter [mm]	Actuator size Ø [mm]	Pilot pressure [bar]	Pressure range [bar]	Article no.
G-Innengewinde						
A (CF A) Pneumatically operated 2/2-way on/off valve Flow direction above seat Normally closed by spring force ¹⁾	Aluminium actuator variant					
	G 1/2	13	80 (F)	4...10	1...600	20093269
	G 1	25	80 (F)	4...10	1...600	20093271
	G 1 1/2	40	80 (F)	4...10	1...600	20093273
	G 2	50	80 (F)	4...10	1...300	20093275
	Nickel-plated brass actuator variant					
	G 1/2	13	50 (D)	4...10	1...300	20093268
	G 1	25	50 (D)	4...10	1...300	20093270
	G 1 1/2	40	50 (D)	4...10	1...200	20093272
	G 2	50	50 (D)	4...10	1...200	20093274

1) Further information can be found in chapter "2. Control functions" on page 4.