



Hydrogen Flanged Particulate Filters

Models | 50H10000F150 to 50H20010F150, 50H10000F300 to 50H20010F300,
100H10000F400 to 100H20010F400, 100H10000F600 to 100H20010F600
Flow Rates 1100 Nm³/hr (647 SCFM) up to 21200 Nm³/hr (12478 SCFM)

Walker Filtration's Class 150, 300, 400 and 600 Hydrogen Flanged Coalescing Filters provide a comprehensive range of high efficiency filters designed to meet the stringent requirements of Hydrogen applications.

Available in three filtration grades of 1, 5 and 25 microns, our hydrogen gas filters provide low pressure drop and offer optimal contamination protection against particle ingress for pressure system components.

Suitable for use with dry hydrogen, these filters are available in a range of flows and pressures to protect the various stages of the developing hydrogen economy. Whatever your requirement, Walker Filtration can support your unique and custom hydrogen filtration solutions.

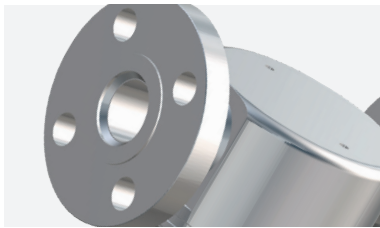

Flexible Installation

All filter housings supplied with ANSI/ASME flanged ports



Superior Filtration Performance

Specialist hydrogen element with high efficiency particle removal down to 1 micron

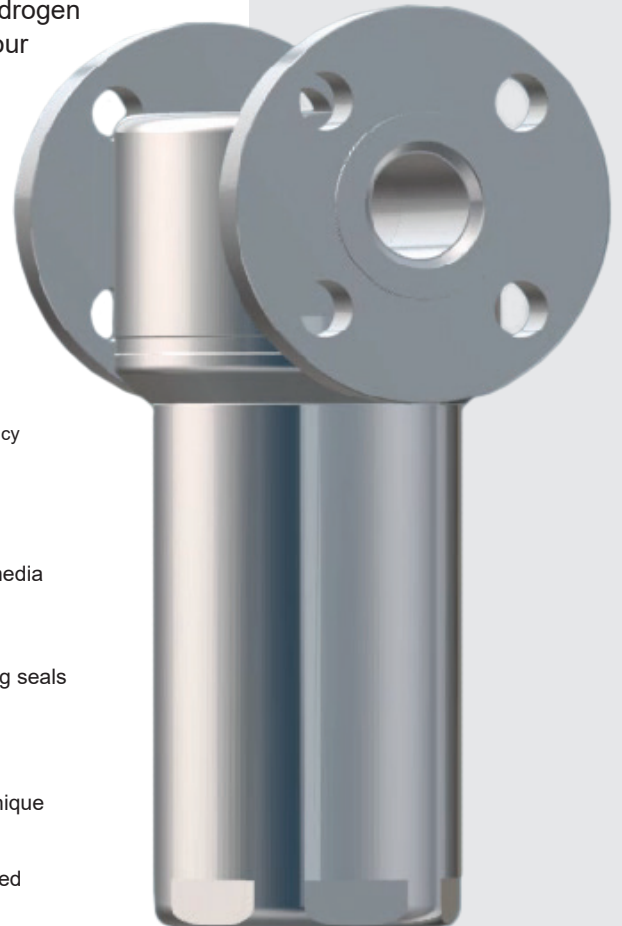

- **Advanced Filtration Technology** Optimum design and high efficiency filtration media provides low pressure losses and increased energy savings in line with air quality standard ISO 8573-1: 2010.
- **O-ring Sealing** Push-fit element design and specialist hydrogen compatible O-ring seals eliminate risk of contaminant bypass.
- **Stainless Steel Element End Caps** On all element models.
- **Simplified Serviceability** Hexagonal spanner locator coupled with the internal unique push fit element ensures a simple, quick and reliable servicing process.
- **Quality Guaranteed** All Hydrogen Filters are manufactured in an ISO 9001 certified factory and are PED compliant. Each filter is hydrostatic tested prior to despatch to guarantee quality and performance.



For further information please call: +44 (0) 191 417 7816

Technical Specification

| Filter model | Pipe size inches | MAWP Barg (psig) | Hydrogen inlet flow rate* | | Dimensions mm (inches) | | | | | Weight | | Element model |
|-----------------------|------------------|------------------|---------------------------|-------|------------------------|------------|------------|------------|-----------|--------|------|------------------|
| | | | Nm ³ /hr | SCFM | A Face to Face | B | C | D | E | kg | lbs | |
| Class 150 | | | | | | | | | | | | |
| 50H10000F150 (Grade) | 1" | 19 (276) | 1100 | 647 | 225 (8.8) | 54 (2.1) | 275 (10.8) | 220 (8.6) | 108 (4.2) | 11.1 | 24.5 | ETG00300 (Grade) |
| 50H15000F150 (Grade) | 1 1/2" | 19 (276) | 2500 | 1471 | 250 (9.8) | 63 (2.5) | 348 (13.7) | 260 (10.2) | 153 (6.0) | 23.3 | 51.3 | ETG00400 (Grade) |
| 50H20000F150 (Grade) | 2" | 19 (276) | 2500 | 1471 | 300 (11.8) | 76 (3.0) | 374 (14.7) | 260 (10.2) | 175 (6.9) | 32.0 | 70.5 | ETG00500 (Grade) |
| 50H20010F150 (Grade) | 2" | 19 (276) | 5000 | 2943 | 300 (11.8) | 76 (3.0) | 554 (21.8) | 450 (17.7) | 175 (6.9) | 38.0 | 83.7 | ETG00600 (Grade) |
| Class 300 | | | | | | | | | | | | |
| 50H10000F300 (Grade) | 1" | 49.6 (719) | 2640 | 1554 | 225 (8.8) | 62 (2.4) | 283 (11.1) | 220 (8.6) | 124 (4.9) | 12.0 | 26.5 | ETG00300 (Grade) |
| 50H15000F300 (Grade) | 1 1/2" | 49.6 (719) | 5500 | 3237 | 250 (9.8) | 77 (3.0) | 362 (14.2) | 260 (10.2) | 155 (6.1) | 25.3 | 55.8 | ETG00400 (Grade) |
| 50H20000F300 (Grade) | 2" | 49.6 (719) | 5500 | 3237 | 300 (11.8) | 82.5 (3.2) | 380 (15.0) | 260 (10.2) | 175 (6.9) | 33.3 | 73.4 | ETG00500 (Grade) |
| 50H20010F300 (Grade) | 2" | 49.6 (719) | 10700 | 6298 | 300 (11.8) | 82.5 (3.0) | 560 (22.0) | 450 (17.7) | 175 (6.9) | 39.5 | 87.0 | ETG00600 (Grade) |
| Class 400 | | | | | | | | | | | | |
| 100H10000F400 (Grade) | 1" | 66.2 (960) | 3000 | 1766 | 225 (8.8) | 62 (2.4) | 283 (11.1) | 220 (8.6) | 124 (4.9) | 12.0 | 26.5 | ETG00300 (Grade) |
| 100H15000F400 (Grade) | 1 1/2" | 66.2 (960) | 8000 | 4709 | 250 (9.8) | 77 (3.0) | 362 (14.2) | 260 (10.2) | 155 (6.1) | 25.3 | 55.8 | ETG00400 (Grade) |
| 100H20000F400 (Grade) | 2" | 66.2 (960) | 8000 | 4709 | 300 (11.8) | 82.5 (3.2) | 380 (15.0) | 260 (10.2) | 175 (6.9) | 33.3 | 73.4 | ETG00500 (Grade) |
| 100H20010F400 (Grade) | 2" | 66.2 (960) | 15000 | 8829 | 300 (11.8) | 82.5 (3.2) | 560 (22.0) | 450 (17.7) | 175 (6.9) | 39.5 | 87.0 | ETG00600 (Grade) |
| Class 600 | | | | | | | | | | | | |
| 100H10000F600 (Grade) | 1" | 66.2 (960) | 5320 | 3078 | 225 (8.8) | 62 (2.4) | 283 (11.1) | 220 (8.6) | 124 (4.9) | 12.0 | 26.5 | ETG00300 (Grade) |
| 100H15000F600 (Grade) | 1 1/2" | 66.2 (960) | 10850 | 6386 | 250 (9.8) | 77 (3.0) | 362 (14.2) | 260 (10.2) | 155 (6.1) | 25.3 | 55.8 | ETG00400 (Grade) |
| 100H20000F600 (Grade) | 2" | 66.2 (960) | 10850 | 6386 | 300 (11.8) | 82.5 (3.2) | 380 (15.0) | 260 (10.2) | 175 (6.9) | 33.3 | 73.4 | ETG00500 (Grade) |
| 100H20010F600 (Grade) | 2" | 66.2 (960) | 21200 | 12478 | 300 (11.8) | 82.5 (3.2) | 560 (22.0) | 450 (17.7) | 175 (6.9) | 39.5 | 87.0 | ETG00600 (Grade) |

* Rated flow at maximum working pressure, reference conditions at 1 bar (a) 20°C

| Grade | RX25 | RX5 | RX1 |
|------------------------|---------------------|----------|----------|
| Particle removal | 25 micron | 5 micron | 1 micron |
| Minimum Temperature | -29°C | -20°F | -29°C |
| Maximum Temperature | 130°C | 266°F | 130°C |
| Element end cap colour | Stainless Steel 316 | | |

| Temperature °C | Pressure – Temperature Rating by Class (ANSI / ASME B16.5 Table 2-2.2 Group 2.2 Material) | | | |
|----------------|--|------|------|------|
| | Class | | | |
| | 150 | 300 | 400 | 600 |
| -29 to 38 | 19.0 | 49.6 | 66.2 | 99.3 |
| 50 | 18.4 | 48.1 | 64.2 | 96.2 |
| 100 | 16.2 | 42.2 | 56.3 | 84.4 |
| 130 | 15.4 | 40.0 | 53.3 | 79.9 |

| Filter Pipe Size Inches | RF Flange Class and PN | |
|-------------------------|---------------------------|---------------|
| | ANSI / ASME B16.5 (Class) | ISO 7005 (PN) |
| 1 | 150, 300, 400, 600 | 20, 50, 110 |
| 1 1/2 | 150, 300, 400, 600 | 20, 50, 110 |
| 2 | 150, 300, 400, 600 | 20, 50, 110 |

| Pressure correction factors | For maximum flow rate, multiply model flow rate by the correction factor corresponding to the minimum operating pressure | | | | | | | | | |
|-----------------------------|--|--------|----------|----------|----------|----------|----------|------|------|------|
| | 4 (58) | 5 (72) | 10 (145) | 12 (174) | 14 (223) | 16 (232) | 19 (275) | | | |
| Class 150 | 0.25 | 0.30 | 0.55 | 0.65 | 0.75 | 0.85 | 1.00 | | | |
| Class 300 | 0.16 | 0.22 | 0.32 | 0.42 | 0.51 | 0.61 | 0.71 | 0.81 | 0.91 | 1.00 |
| Class 400 | 0.12 | 0.31 | 0.46 | 0.54 | 0.61 | 0.69 | 0.76 | 0.84 | 0.91 | 1.00 |
| Class 600 | 0.08 | 0.21 | 0.31 | 0.41 | 0.51 | 0.61 | 0.71 | 0.81 | 0.91 | 1.00 |

Technical Notes

- Direction of flow is out to in through the filter element.
- All Hydrogen Filters are supplied without a drain port/plug.
- Hydrogen Filters are manufactured from grade 316 Stainless steel and are PED 2014/68/EU compliant for group 1 gases.
- Flanged connections are raised face type to ANSI / ASME B16.5 (ISO 7005 (PN) Equivalents) to Table 2-2.2 Group 2.2 Material.
- Filter elements should be changed every 12 months/ 8000 hours (whichever comes first).

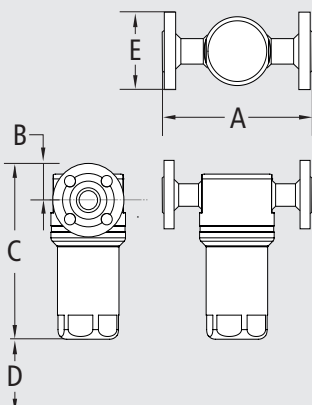

50H10000FXXX -
100H20010FXXX



Walker Filtration Ltd Birtley Road, Washington, Tyne & Wear, NE38 9DA, United Kingdom.

tel: +44 (0) 191 417 7816 fax: +44 (0) 191 415 3748 email: sales@walkerfiltration.co.uk web: www.walkerfiltration.com